

KEITHLEY INSTRUMENTS

Model 3940 Multifunction Synthesizer Service Manual

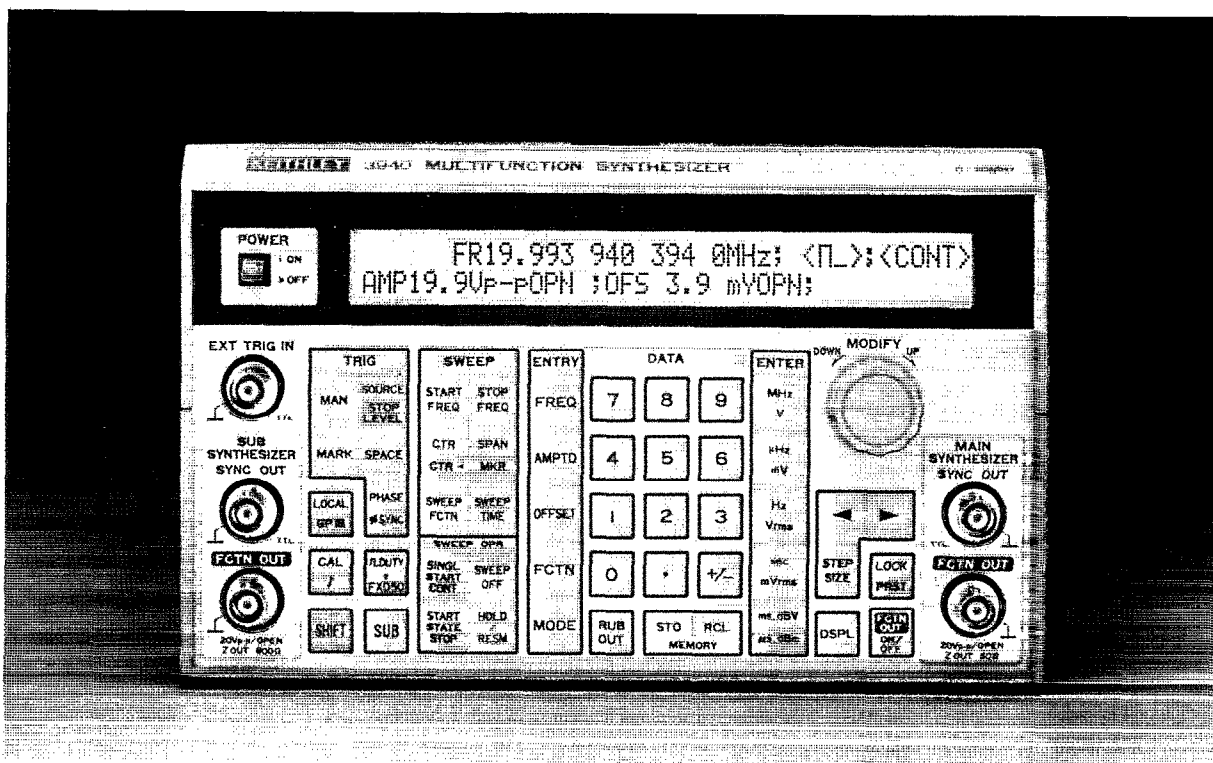

Contains Servicing Information

Publication Date: August 1991

Document Number: 3940-902-01 Rev. A

WARRANTY

Keithley Instruments, Inc. warrants this product to be free from defects in material and workmanship for a period of 1 year from date of shipment.

Keithley Instruments, Inc. warrants the following items for 90 days from the date of shipment: probes, cables, rechargeable batteries, diskettes, and documentation.

During the warranty period, we will, at our option, either repair or replace any product that proves to be defective.

To exercise this warranty, write or call your local Keithley representative, or contact Keithley headquarters in Cleveland, Ohio. You will be given prompt assistance and return instructions. Send the product, transportation prepaid, to the indicated service facility. Repairs will be made and the product returned, transportation prepaid. Repaired or replaced products are warranted for the balance of the original warranty period, or at least 90 days.

LIMITATION OF WARRANTY

This warranty does not apply to defects resulting from product modification without Keithley's express written consent, or misuse of any product or part. This warranty also does not apply to fuses, software, non-rechargeable batteries, damage from battery leakage, or problems arising from normal wear or failure to follow instructions.

THIS WARRANTY IS IN LIEU OF ALL OTHER WARRANTIES, EXPRESSED OR IMPLIED, INCLUDING ANY IMPLIED WARRANTY OF MERCHANTABILITY OR FITNESS FOR A PARTICULAR USE. THE REMEDIES PROVIDED HEREIN ARE BUYER'S SOLE AND EXCLUSIVE REMEDIES.

NEITHER KEITHLEY INSTRUMENTS, INC. NOR ANY OF ITS EMPLOYEES SHALL BE LIABLE FOR ANY DIRECT, INDIRECT, SPECIAL, INCIDENTAL OR CONSEQUENTIAL DAMAGES ARISING OUT OF THE USE OF ITS INSTRUMENTS AND SOFTWARE EVEN IF KEITHLEY INSTRUMENTS, INC., HAS BEEN ADVISED IN ADVANCE OF THE POSSIBILITY OF SUCH DAMAGES. SUCH EXCLUDED DAMAGES SHALL INCLUDE, BUT ARE NOT LIMITED TO: COSTS OF REMOVAL AND INSTALLATION, LOSSES SUSTAINED AS THE RESULT OF INJURY TO ANY PERSON, OR DAMAGE TO PROPERTY.

KEITHLEY INSTRUMENTS

Instruments Division, Keithley Instruments, Inc. • 28775 Aurora Road • Cleveland, Ohio 44139 • (216) 248-0400 • Fax: 248-6168

WEST GERMANY: Keithley Instruments GmbH • Heiglhofstr. 5 • Munchen 70 • 089-71002-0 • Telex: 52-12160 • Fax: 089-7100259
GREAT BRITAIN: Keithley Instruments, Ltd. • The Minster • 58, Portman Road • Reading, Berkshire RG 3 1EA • 011 44 734 575 666 • Fax: 011 44 734 596 469
FRANCE: Keithley Instruments SARL • 3 Allee des Garays • B.P. 60 • 91124 Palaiseau/Z.I. • 1-6-0115 155 • Telex: 600 933 • Fax: 1-6-0117726
NETHERLANDS: Keithley Instruments BV • Avelingen West 49 • 4202 MS Gorinchem • P.O. Box 559 • 4200 AN Gorinchem • 01830-35333 • Telex: 24 684 • Fax: 01830-30821
SWITZERLAND: Keithley Instruments SA • Kriesbachstr. 4 • 8600 Dubendorf • 01-821-9444 • Telex: 828 472 • Fax: 0222-315366
AUSTRIA: Keithley Instruments GesmbH • Rosenhugelstrasse 12 • A-1120 Vienna • (0222) 84 65 48 • Telex: 131677 • Fax: (0222) 8403597
ITALY: Keithley Instruments SRL • Viale S. Cimignano 4/A • 20146 Milano • 02-4120360 or 02-4156540 • Fax: 02-4121249

**Service Manual
Model 3940
Multifunction Synthesizer**

**©1991, Keithley Instruments, Inc.
All Rights Reserved
Instruments Division
Cleveland, Ohio, U. S. A.
Document Number: 3940-902-01**

Safety Precautions

The following safety precautions should be observed before using the Model 3940 Multifunction Synthesizer and any associated instruments.

This instrument is intended for use by qualified personnel who recognize shock hazards and are familiar with the safety precautions required to avoid possible injury. Read over this manual carefully before using the instrument.

Exercise extreme caution when a shock hazard is present at the test circuit. The American National Standards Institute (ANSI) states that a shock hazard exists when voltage levels greater than 30V rms or 42.4V peak are present. **A good safety practice is to expect that hazardous voltage is present in any unknown circuit before measuring.**

Inspect the connecting cables and test leads for possible wear, cracks, or breaks before each use.

For maximum safety, do not touch the test cables or any instruments while power is applied to the circuit under test. Turn off the power and discharge any capacitors before connecting or disconnecting cables from the instrument.

Do not touch any object which could provide a current path to the common side of the circuit under test or power line (earth) ground. Always make measurements with dry hands while standing on a dry, insulated surface capable of withstanding the voltage being measured.

Instrumentation and accessories should not be connected to humans.

HOW TO USE THIS MANUAL

Details procedures to verify that the instrument meets stated specifications.

SECTION 1 **Performance Verification**

Describes basic operating principles for the various circuits in the Model 3940.

SECTION 2 **Principles of Operation**

Covers fuse replacement, calibration and repair of the instrument, and lists replacement parts.

SECTION 3 **Service Information**

WARNING

The information in this manual is intended for qualified service personnel who can recognize possible shock hazards. Do not attempt these procedures unless you are qualified to do so.

Table of Contents

SECTION 1 — Performance Verification

1.1	INTRODUCTION	1-1
1.2	ENVIRONMENTAL CONDITIONS	1-1
1.3	INITIAL CONDITIONS	1-1
1.4	LINE POWER VOLTAGE	1-1
1.5	RECOMMENDED TEST EQUIPMENT	1-1
1.6	VERIFICATION PROCEDURES	1-2
1.6.1	Frequency and Duty Cycle Accuracy	1-2
1.6.2	Amplitude Accuracy	1-4
1.6.3	Frequency Response (Sine)	1-6
1.6.4	Frequency Response (Triangle, Sawtooth, Square)	1-7
1.6.5	Frequency Response (Sub Sine)	1-8
1.6.6	Total Harmonic Distortion	1-8
1.6.7	DC Voltage Accuracy	1-10
1.6.8	DC Level (Square) and DC Offset Error (Sine)	1-11

SECTION 2 — Principles of Operation

2.1	INTRODUCTION	2-1
2.2	BLOCK DIAGRAM	2-1
2.2.1	Control Section	2-1
2.2.2	Display and Keyboard Section	2-1
2.2.3	Trigger Section	2-1
2.2.4	Sweep Section	2-1
2.2.5	GPIB Interface	2-1
2.2.6	Sub Synthesizer	2-3
2.2.7	Main Synthesizer	2-3
2.2.8	Power Supply	2-3
2.3	MAIN SYNTHESIZER DESCRIPTION	2-3
2.3.1	Main Synthesizer Block Diagram	2-3
2.3.2	D/A Converter	2-3
2.3.3	Square Wave Generator	2-3
2.3.4	Amplitude Control	2-3
2.3.5	Output Amplifier	2-3
2.3.6	Calibration	2-3
2.4	SYNTHESIZER OPERATING PRINCIPLES	2-5

SECTION 3 — Service Information

3.1	INTRODUCTION	3-1
3.2	LINE FUSE REPLACEMENT	3-1
3.3	CALIBRATION	3-1
3.3.1	Environmental Conditions	3-2

3.3.2	Initial Conditions	3-2
3.3.3	Line Power	3-2
3.3.4	Recommended Calibration Equipment	3-2
3.3.5	Cover Removal	3-2
3.3.6	Calibration Adjustments	3-3
3.3.7	Calibration Procedures	3-6
3.3.8	Cover Replacement	3-8
3.4	FAN FILTER CLEANING	3-9
3.5	RECHARGEABLE BATTERY REPLACEMENT	3-9
3.6	REPAIR	3-9
3.6.1	Factory Service	3-9
3.6.2	Power Supply Test Points	3-9
3.6.3	Board-Level Repair	3-11
3.7	REPLACEABLE PARTS	3-11
3.7.1	Parts List	3-11
3.7.2	Ordering Parts	3-11

APPENDICES

- A Typical Data
- B Model 3940 Specifications

List of Illustrations

SECTION 1 — Performance Verification

Figure 1-1	Connections to Timer/Counter	1-3
Figure 1-2	Connections to Model 197A DMM	1-4
Figure 1-3	Connections to Wideband AC DVM	1-6
Figure 1-4	Connections to Audio Analyzer	1-9

SECTION 2 — Principles of Operation

Figure 2-1	Overall Block Diagram	2-2
Figure 2-2	Main Synthesizer Block Diagram	2-4
Figure 2-3	Frequency Synthesizer Address Generator Diagram	2-5
Figure 2-4	Address Generator Waveform	2-6
Figure 2-5	Waveform Memory and D/A Converter	2-6

SECTION 3 — Service Information

Figure 3-1	Cover Removal	3-3
Figure 3-2	Analog Board (NP-10375) Calibration Adjustments	3-4
Figure 3-3	Control Board (NP-21007) Calibration Adjustments	3-5
Figure 3-4	Sub Synthesizer Output Connections to Model 197A DMM	3-6
Figure 3-5	Main Synthesizer Output Connections to Timer/Counter	3-7
Figure 3-6	Main Synthesizer Output Connections to DMM	3-7
Figure 3-7	DMM Connections to DC OFS and GND Test Points	3-8
Figure 3-8	Power Supply Test Points	3-10
Figure 3-9	Model 3940 Exploded View	3-12

List of Tables

SECTION 1 — Performance Verification

Table 1-1	Verification Equipment	1-2
Table 1-2	Limits for Frequency and Duty Cycle Accuracy	1-3
Table 1-3	Limits for Amplitude Accuracy	1-5
Table 1-4	Limits for Frequency Response (Sine)	1-7
Table 1-5	Limits for Frequency Response (Triangle, Sawtooth, Square)	1-7
Table 1-6	Limits for Frequency Response (Sub Sine)	1-8
Table 1-7	Limits for Total Harmonic Distortion	1-10
Table 1-8	Limits for DC Voltage Accuracy	1-10
Table 1-9	Limits for DC Level (Square) and DC Offset Error (Sine)	1-11

SECTION 3 — Service Information

Table 3-1	Recommended Line Fuses	3-1
Table 3-2	Recommended Test Equipment for Calibration	3-2
Table 3-3	Board Level Repair Summary	3-11
Table 3-4	Replaceable Parts	3-11

SECTION 1

Performance Verification

1.1 INTRODUCTION

The procedures outlined in this section may be used to verify that the instrument is operating within the limits stated in the specifications. Performance verification may be done when the instrument is first received to ensure that no damage or misadjustment has occurred during shipment. Verification may also be performed whenever there is a question of instrument accuracy, or following calibration, if desired.

NOTE

If the instrument is still under warranty (less than one year from the date of shipment), and its performance falls outside the specified range, contact your Keithley representative or the factory to determine the correct course of action.

1.2 ENVIRONMENTAL CONDITIONS

All measurements should be made at 18-28°C (65-82°F) and at less than 70% relative humidity.

1.3 INITIAL CONDITIONS

The Model 3940 must be turned on and allowed to warm up for at least one hour before beginning the verification

procedures. If the instrument has been subjected to extremes of temperature (outside the range specified in the previous paragraph), additional time should be allowed for internal temperatures to reach normal operating temperature. Typically, it takes one additional hour to stabilize a unit that is 10°C (18°F) outside the specified temperature range.

1.4 LINE POWER VOLTAGE

Before performance verification, be sure the line voltage selector switch setting is set to the correct position. Tests should be performed with the instrument operating on a line voltage within 10% of the set voltage and at a line frequency from 48 to 62Hz.

1.5 RECOMMENDED TEST EQUIPMENT

Table 1-1 lists all the test equipment needed for verification. The procedure for performance verification is based on using this exact equipment.

NOTE

The verification limits reflect only the accuracy specifications of the Model 3940. They do not include test equipment tolerance.

Alternate equipment may be used as long as the substitute equipment has specifications at least as good as those listed in Table 1-1.

Table 1-1. Verification Equipment

Manufacturer	Model	Description	Specifications
Keithley	197A	DMM (DC volts, AC volts) (5-1/2 digits)	20V range; $\pm(0.015\%$ of rdg + 3 counts)
Fluke	8920A	DVM (AC volts) (3-1/2 digits)	ACV; $\pm(0.35\%$ of rdg + 100 counts)
Philips	PM 6654C	Timer/Counter	20V range; 1kHz-200kHz (0.5% of rdg), 200kHz-1MHz (0.7%), 1-10MHz (3%), 10-20MHz (5%)
Panasonic	PM 9678	TCXO option	0.01Hz-120MHz; time base aging
	VP-7722A	Audio Analyzer	$<1 \times 10^{-7}$ /month; Vp-p measurements
Keithley	7051-2	BNC Interconnect Cable	10Hz-110kHz; 0.001% at full scale; ± 1 dB harmonic distortion accuracy from 10Hz to 15.99kHz
Keithley	7755	50 Ω Feed-through Terminator	50 Ω coaxial cable (RG-58C), male BNC connectors, 2ft (0.6m)
Pomona	1468	BNC-banana Adapter	BNC to BNC adapter, 50 Ω termination, DC to 250MHz, VSWR of <1.1
			Female BNC connector to double banana plug

1.6 VERIFICATION PROCEDURES

The following paragraphs contain the detailed procedures for verifying accuracy specifications of the Model 3940 using the equipment listed in Table 1-1. The allowable reading limits in these procedures do not include error that could be contributed by this equipment.

These procedures are intended for use only by qualified personnel using accurate and reliable test equipment. If the instrument is out of specifications and not under warranty, refer to the calibration information in Section 3.

1.6.1 Frequency and Duty Cycle Accuracy

1. Connect the function synthesizer to a timer/counter as shown in Figure 1-1. Turn on both instruments.
2. Restore factory defaults on the Model 3940 by pressing SHIFT PRST.
3. Program a 10MHz sine function of 20Vp-p.
4. Set the timer/counter to display the frequency at Channel A, and verify that the frequency reading is within the limits specified in Table 1-2.
5. Program a 1kHz square wave with a fixed 50% duty cycle.
6. Set the timer/counter to display the pulse width of Channel A, and verify that the reading is within specifications.
7. Modify the frequency and duty cycle settings of the main synthesizer according to Table 1-2 and verify the pulse width readings.

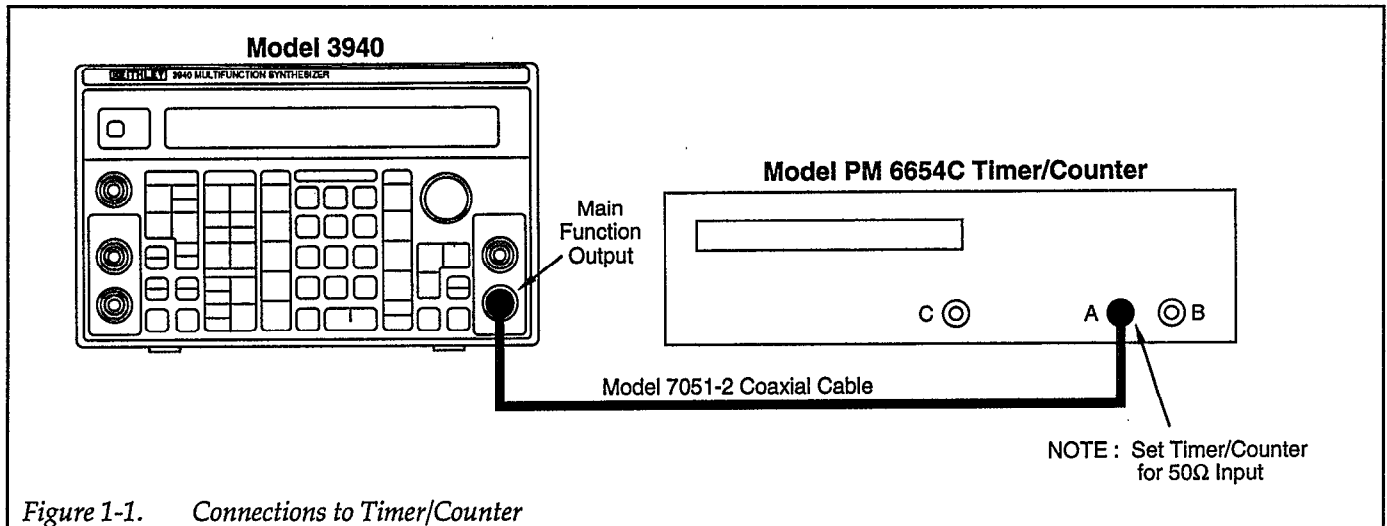

Figure 1-1. Connections to Timer/Counter

Table 1-2. Limits for Frequency and Duty Cycle Accuracy

Synthesizer	Function	Amplitude	Frequency	Allowable Reading (18°C to 28°C)
Main	Sine	20Vp-p	10MHz	9.99995MHz to 10.00005MHz
Main	Square (FXD50)	20Vp-p	1kHz	498.5μsec to 501.5μsec
			10kHz	49.85μsec to 50.15μsec
			100kHz	4.985μsec to 5.015μsec
			500kHz	0.98μsec to 1.02μsec
			1MHz	490nsec to 510nsec
Main	Square (VAR 5) (VAR50) (VAR95)	20Vp-p	1kHz	49.5μsec to 50.5μsec
				495μsec to 505μsec
				940.5μsec to 959.5μsec
Main	Square (VAR50)	20Vp-p	10kHz	49.5μsec to 50.5μsec
			100kHz	4.95μsec to 5.05μsec
			500kHz	0.99μsec to 1.01μsec
			1MHz	495nsec to 505nsec

1.6.2 Amplitude Accuracy

1. Connect the function synthesizer to a DMM as shown in Figure 1-2A. Turn on both instruments.
2. Restore factory defaults on the Model 3940 by pressing SHIFT PRST.
3. Program a 1kHz sine function of 20Vp-p.
4. Set the DMM to measure AC volts with autoranging, and verify that the voltage reading is within the limits specified in Table 1-3.
5. Change the function, frequency, and amplitude settings of the main and sub synthesizers according to Table 1-3, and verify the voltage readings. When verifying subsynthesizer accuracy, switch the coaxial cable to the subsynthesizer function out jack. (See Figure 1-2B.)

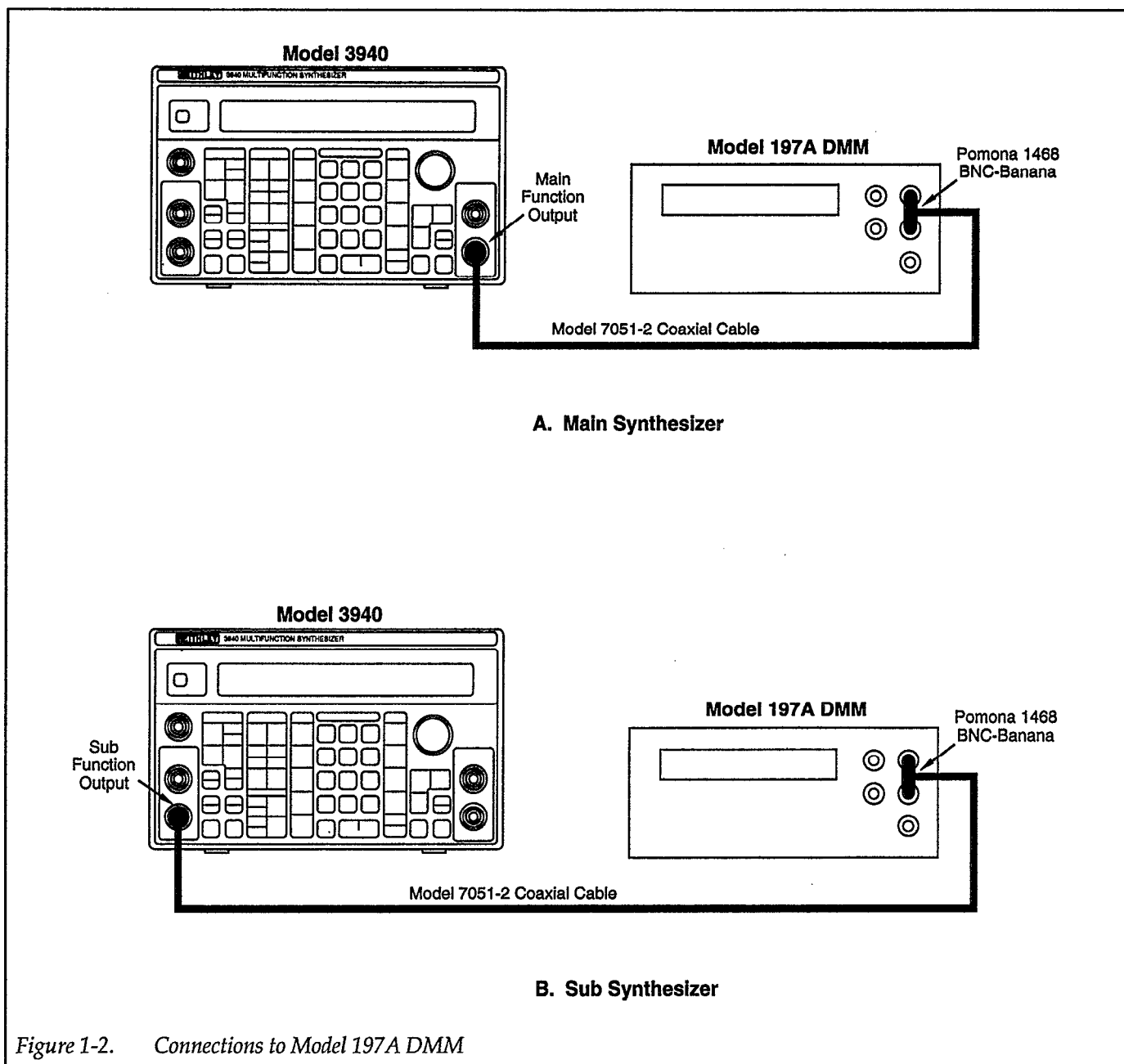

Figure 1-2. Connections to Model 197A DMM

Table 1-3. Limits for Amplitude Accuracy

Synthesizer	Function	Frequency	Amplitude	Allowable Reading (18°C to 28°C)
Main	Sine	1kHz 10kHz	20.0Vp-p	6.9297Vrms to 7.2124Vrms 6.9297Vrms to 7.2124Vrms
Main	Sine	1kHz	15.0Vp-p 11.3Vp-p 11.2Vp-p 6.29Vp-p 3.55Vp-p 2.01Vp-p 2.00Vp-p 200mVp-p	5.1973Vrms to 5.4093Vrms 3.9153Vrms to 4.0750Vrms 3.8807Vrms to 4.0389Vrms 2.1794Vrms to 2.2683Vrms 1.2301Vrms to 1.2802Vrms 0.6965Vrms to 0.7248Vrms 0.6789Vrms to 0.7353Vrms 0.0665Vrms to 0.0749Vrms
Sub	Sine	1kHz	20.0Vp-p 15.0Vp-p 10.0Vp-p 5.00Vp-p	6.8590Vrms to 7.2831Vrms 5.1443Vrms to 5.4623Vrms 3.4295Vrms to 3.6415Vrms 1.7148Vrms to 1.8207Vrms
Main	Triangle	1kHz	20.0Vp-p	5.6003Vrms to 5.9467Vrms
Main	Square (VAR50) (FXD50)	1kHz	20.0Vp-p	9.80Vrms to 10.2Vrms 9.80Vrms to 10.2Vrms
Main	Sawtooth Up Sawtooth Down	1kHz	20.0Vp-p	5.6003Vrms to 5.9467Vrms 5.6003Vrms to 5.9467Vrms
Sub	Triangle Square Sawtooth Up Sawtooth Down	1kHz	20.0Vp-p	5.6003Vrms to 5.9467Vrms 9.7Vrms to 10.3Vrms 5.6003Vrms to 5.9467Vrms 5.6003Vrms to 5.9467Vrms

1.6.3 Frequency Response (Sine)

1. Connect the function synthesizer to a wideband AC DVM as shown in Figure 1-3A. Turn on both instruments.
2. Restore factory defaults on the Model 3940 by pressing SHIFT PRST.
3. Program a 1kHz sine function of 20Vp-p.
4. Set the DVM to measure AC volts with autoranging, and verify that the voltage reading is within the limits specified in Table 1-4.
5. Set the DVM to measure dB and select a 50Ω reference impedance. Press REL to establish the present voltage reading as the relative dB reference.
6. Change the frequency setting of the main synthesizer according to Table 1-4, and verify the subsequent ±dB readings.

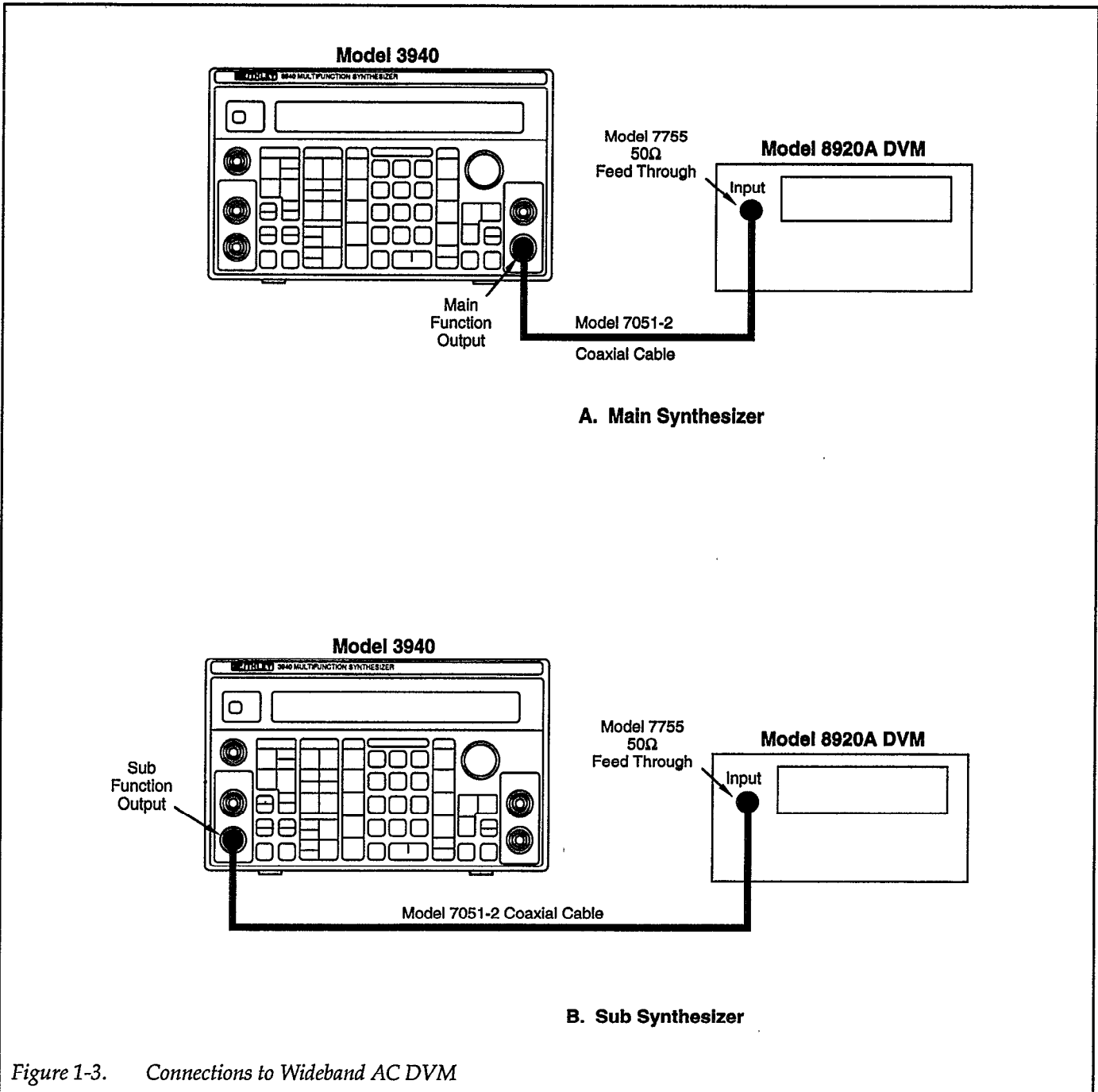

Figure 1-3. Connections to Wideband AC DVM

Table 1-4. Limits for Frequency Response (Sine)

Synthesizer	Function	Amplitude	Frequency	Allowable Reading (18°C to 28°C)
Main	Sine	20Vp-p	1kHz	3.4649Vrms to 3.6062Vrms (=REF)
			100kHz	+0.3dB to -0.3dB
			1MHz	+0.3dB to -0.3dB
			2MHz	+0.3dB to -0.5dB
			3.5MHz	+0.3dB to -0.5dB
			5MHz	+0.3dB to -0.5dB
			7MHz	+0.3dB to -0.5dB
			10MHz	+0.3dB to -1.0dB
			15MHz	+0.3dB to -2.5dB
			20MHz	+0.3dB to -2.5dB

1.6.4 Frequency Response (Triangle, Sawtooth, Square)

1. Connect the function synthesizer to a timer/counter as shown in Figure 1-1. Turn on both instruments.
2. Restore factory defaults on the Model 3940 by pressing SHIFT PRST.
3. Program a 1kHz triangle wave of 18Vp-p.
4. Set the timer/counter to display the peak-to-peak voltage at Channel A, and verify that the voltage reading is within the limits specified in Table 1-5. Call this reading REF.
5. Change the frequency to 50kHz. The new reading should be between 0.97 times the REF reading and 1.03 times the REF reading.
6. Modify the frequency and function settings of the main synthesizer according to Table 1-5 and verify that the corresponding readings are within the specified limits.

Table 1-5. Limits for Frequency Response (Triangle, Sawtooth, Square)

Synthesizer	Function	Amplitude	Frequency	Allowable Reading (18°C to 28°C)
Main	Triangle	18Vp-p	1kHz	8.73Vp-p to 9.27Vp-p (=REF)
			50kHz	0.97 × REF to 1.03 × REF
			100kHz	0.97 × REF to 1.03 × REF
Main	Sawtooth Up	18Vp-p	1kHz	8.73Vp-p to 9.27Vp-p (=REF)
			50kHz	0.95 × REF to 1.05 × REF
			100kHz	0.95 × REF to 1.05 × REF
Main	Sawtooth Down	18Vp-p	1kHz	8.73Vp-p to 9.27Vp-p (=REF)
			50kHz	0.95 × REF to 1.05 × REF
			100kHz	0.95 × REF to 1.05 × REF
Main	Square	18Vp-p	1kHz	8.82Vp-p to 9.18Vp-p (=REF)
			50kHz	0.97 × REF to 1.03 × REF
			100kHz	0.97 × REF to 1.03 × REF
			1MHz	0.97 REF to 1.03 × REF

1.6.5 Frequency Response (Sub Sine)

1. Connect the function synthesizer to a wideband AC DVM as shown in Figure 1-3B. Turn on both instruments.
2. Restore factory defaults on the Model 3940 by pressing SHIFT PRST.
3. Program a 1kHz sine function of 20Vp-p.
4. Set the DVM to measure AC volts with autoranging, and verify that the voltage reading is within the limits specified in Table 1-6.
5. Set the DVM to measure dB and select a 50Ω reference impedance. Press REL to establish the present voltage reading as the relative dB reference.
6. Change the frequency setting of the sub synthesizer according to Table 1-6, and verify the subsequent ±dB readings.

1.6.6 Total Harmonic Distortion

1. Connect the function synthesizer to an audio analyzer as shown in Figure 1-4A. Turn on both instruments.
2. Restore factory defaults on the Model 3940 by pressing SHIFT PRST.
3. Program a 1kHz sine function of 20Vp-p.
4. Set the audio analyzer to measure distortion, and verify that the reading is within the limits specified in Table 1-7.
5. Change the frequency setting of the main and sub synthesizers according to Table 1-7, and verify the distortion readings. When verifying subsynthesizer distortion, switch the coaxial cable to the subsynthesizer function out jack. (See Figure 1-4B.)

Table 1-6. Limits for Frequency Response (Sub Sine)

Synthesizer	Function	Amplitude	Frequency	Allowable Reading (18°C to 28°C)
Sub	Sine	20Vp-p	1kHz	6.8590Vrms to 7.2831Vrms (=REF)
			10kHz	+0.3dB to -0.3dB
			20kHz	+0.3dB to -0.3dB
			50kHz	+0.3dB to -0.3dB
			70kHz	+1.0dB to -2.0dB
			100kHz	+1.0dB to -2.0dB

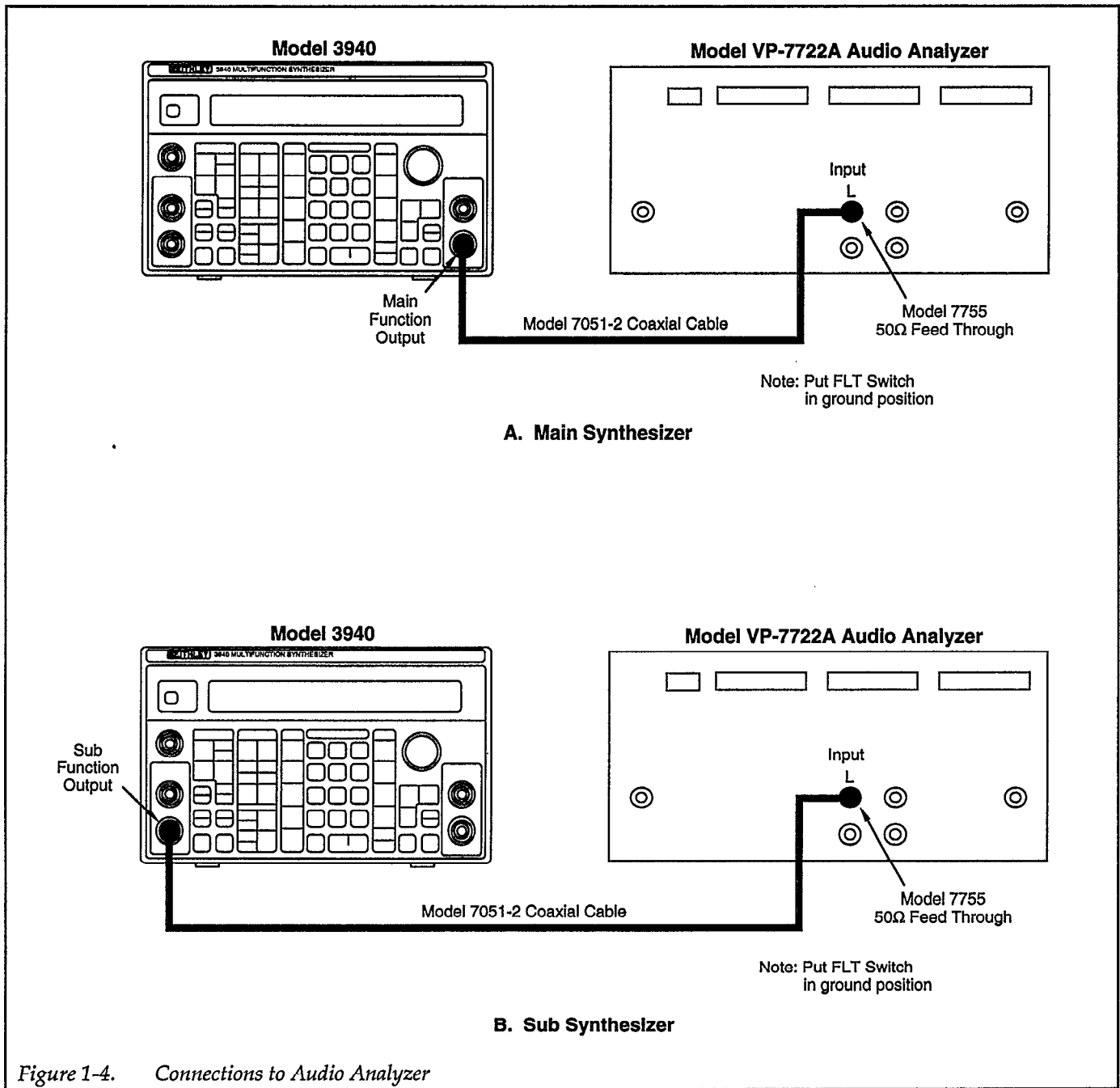

Figure 1-4. Connections to Audio Analyzer

Table 1-7. Limits for Total Harmonic Distortion

Synthesizer	Function	Amplitude	Frequency	Allowable Reading (18°C to 28°C)
Main	Sine	20Vp-p	1kHz	< 0.3%
			10kHz	< 0.3%
			20kHz	< 0.3%
			35kHz	< 0.3%
			50kHz	< 0.3%
			70kHz	< 0.3%
			100kHz	< 0.3%
Sub	Sine	20Vp-p	1kHz	< 0.2%
			5kHz	< 0.2%
			10kHz	< 0.3%
			20kHz	< 0.3%
			35kHz	< 0.3%
			50kHz	< 0.3%
			70kHz	< 0.3%
			100kHz	< 0.3%

1.6.7 DC Voltage Accuracy

1. Connect the function synthesizer to a DMM as shown in Figure 1-2A. Turn on both instruments.
2. Restore factory defaults on the Model 3940 by pressing SHIFT PRST.
3. Program the DC function, 0Hz, 2.00mV amplitude, with +10.0V offset.
4. Set the DMM to measure DC volts with autoranging, and verify that the voltage reading is within the limits specified in Table 1-8.
5. Change the offset setting of the main synthesizer according to Table 1-8 and verify the subsequent voltage readings.

Table 1-8. Limits for DC Voltage Accuracy

Synthesizer	Function	Offset	Allowable Reading (18°C to 28°C)
Main	DC	+10.0V	9.88V to 10.12V
		-10.0V	-9.88V to -10.12V
		+5.00V	4.93V to 5.07V
		-5.00V	-4.93V to -5.07V
		+2.50V	2.455V to 2.545V
		-2.50V	-2.455V to -2.545V
		+1.01V	0.9799V to 1.0401V
		-1.01V	-0.9799V to -1.0401V

1.6.8 DC Level (Square) and DC Offset Error (Sine)

1. Connect the function synthesizer to a DMM as shown in Figure 1-2A. Turn on both instruments.
2. Restore factory defaults on the Model 3940 by pressing SHIFT PRST.
3. Program a 20Vp-p square wave, gated mode, Ext ∇ trigger source, and +90° phase.
4. Set the DMM to measure DC volts with autoranging, and verify that the voltage reading is within the limits specified in Table 1-9.
5. Change the function, amplitude, mode, trigger source, and phase settings of the main and sub synthesizers according to Table 1-9, and verify the voltage readings. When verifying subsynthesizer accuracy, switch the coaxial cable to the subsynthesizer function out jack. (See Figure 1-2B.)

Table 1-9. Limits for DC Level (Square) and DC Offset Error (Sine)

Synthesizer	Function	Amplitude	Mode	Trigger Source	Phase	Allowable Reading (18°C to 28°C)
Main	Square	20Vp-p	Gate	Ext ∇	+90° -90°	9.8V to 10.2V -9.8V to -10.2V
Main	Sine	20Vp-p 2.01Vp-p	Gate	Ext ∇	0°	±120mV ±30mV
Sub*	Sine	2.00Vp-p 2.00Vp-p	Cont.	Int ∇	0°	±60mV ±20mV

* Note: Function Out is OFF for Sub Synthesizer test.

SECTION 2

Principles of Operation

2.1 INTRODUCTION

This section covers basic operating principles of the Model 3940.

2.2 BLOCK DIAGRAM

Figure 2-1 shows an overall block diagram of the Model 3940. The various sections include the control section, display and keyboard section, trigger section, sweep input and output blocks, the GPIB interface, main and sub synthesizer sections, analog section, and the power supply.

2.2.1 Control Section

The control section supervises all instrument operations. The control section includes the 68000 microprocessor, EPROM for program storage, and battery backed-up RAM for working storage and memory to store operating parameters.

2.2.2 Display and Keyboard Section

This section includes a 40-character X 2-line LCD (liquid crystal display) and a membrane keyboard. The LCD is backlit for better visibility.

The keyboard includes a membrane keyboard, the MODIFY knob, and its interface.

2.2.3 Trigger Section

The trigger section generates trigger signals for trigger and gate oscillation modes.

2.2.4 Sweep Section

The sweep block performs sweep-related input and output functions. Circuits included in this section are the I/O buffer, interface, D/A converter for X drive, and the analog section.

2.2.5 GPIB Interface

The GPIB interface allows the instrument to be connected to the IEEE-488 bus. Many functions such as handshaking are controlled automatically by the interface, minimizing microprocessor time necessary to control the bus.

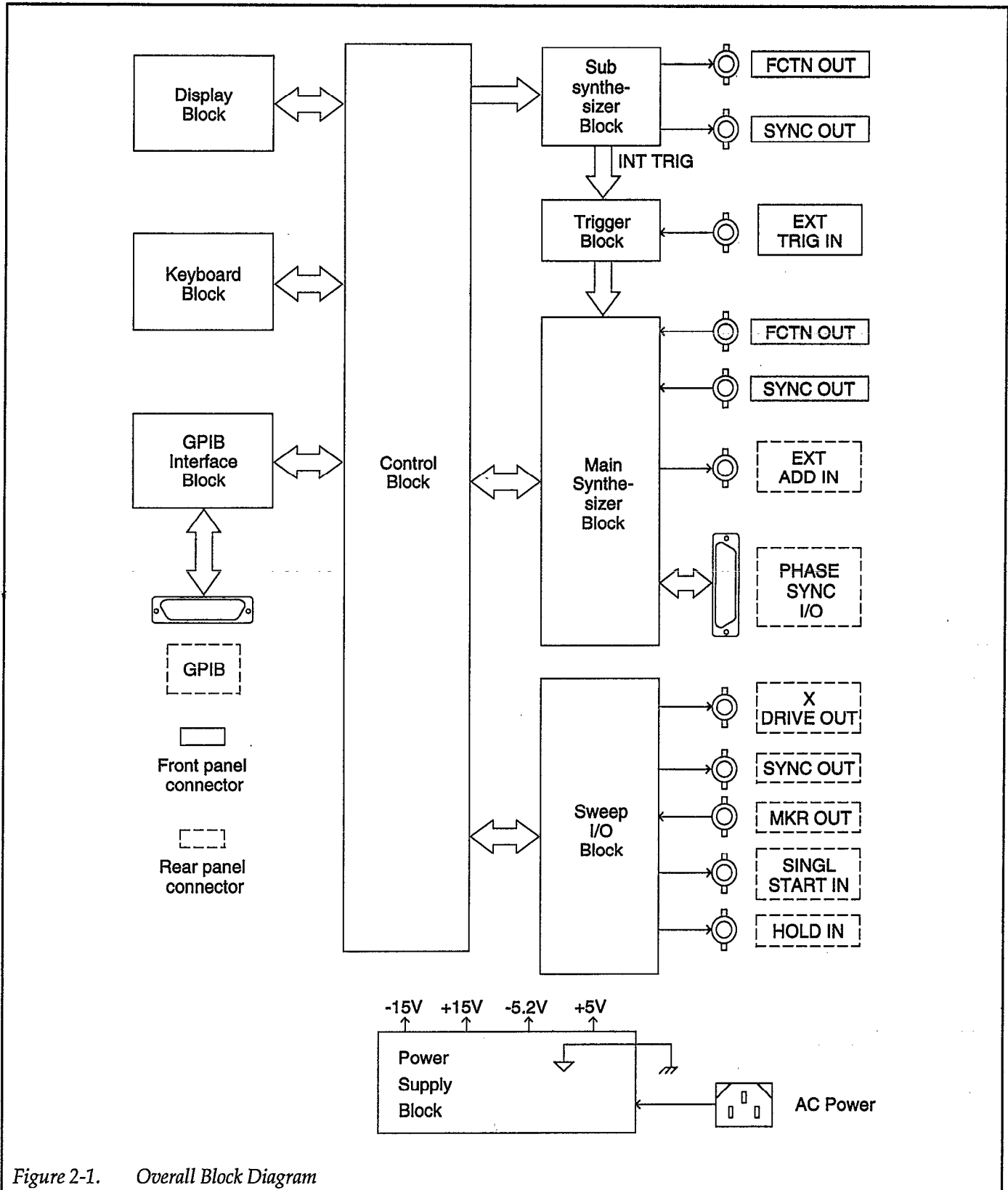

Figure 2-1. Overall Block Diagram

2.2.6 Sub Synthesizer

The sub synthesizer is comprised of a custom LSI IC, which provides direct digital synthesis of the selected waveform. In addition to the custom LSI IC, the synthesizer section also includes a ROM for waveform data, a D/A converter, amplitude control and output amplifier circuits.

The clock signal, which provides the time base for the oscillation frequencies, is derived from the main synthesizer.

2.2.7 Main Synthesizer

The main synthesizer includes a custom LSI IC, which directly synthesizes the waveform and a high-accuracy crystal oscillator as the time base. Additional main synthesizer circuits include the RAM for waveform data, D/A converter, and analog circuits.

The analog circuits include a square wave generator, amplitude control, output amplifier, and attenuator.

2.2.8 Power Supply

The power supply converts the AC line power to DC voltages used by the various circuits within the instrument. The supply includes a transformer, series regulator, as well as a switching regulator used for logic circuits.

Note that power supply common is connected to chassis ground.

2.3 MAIN SYNTHESIZER DESCRIPTION

2.3.1 Main Synthesizer Block Diagram

Figure 2-2 shows a block diagram of the main. Key sections include the synthesizer itself, the D/A converter, square wave generator, D/A and attenuator for amplitude and DC offset control.

2.3.2 D/A Converter

Digital data from the synthesizer is converted into waveform data by the waveform RAM. This waveform

data is then converted into an analog signal by the D/A converter. The converted signal is then passed through a low-pass filter to remove any spurious components. This conversion process is used to generate sine, triangular, and sawtooth waves.

2.3.3 Square Wave Generator

Square waves with frequencies greater than 100kHz with fixed 50% duty cycle are generated by applying sine waves to an analog comparator. The analog comparator has a certain amount of hysteresis, which results in good-quality square waves at the output.

50% duty cycle square waves with frequencies less than 100kHz and all variable duty cycle square waves are generated from signals generated by the synthesizer LSI IC.

2.3.4 Amplitude Control

Control of amplitude for normal waveforms is performed by the A/D converter. The square wave generator controls the amplitude of square waves.

Waveforms already attenuated from 0dB to -5dB are further reduced in amplitude using attenuators of 5dB, 10dB, and 20dB. Using these combined attenuation factors, overall attenuation factors of 40dB (1:100) are possible.

2.3.5 Output Amplifier

The generated waveform is applied to the output amplifier along with the DC offset signal and any applied external additive input signal (EXT ADD IN) and then amplified. The output amplifier feeds the output attenuator, which combines 20dB and 40dB attenuation units to provide reduction ratios of 1:1, 1:10, 1:100, and 1:1000.

2.3.6 Calibration

Calibration, which is provided to correct for amplitude and offset errors, is performed using a comparator and a D/A converter to compare the DC offset with a stored reference value. During calibration, the amplitude is adjusted so that the output amplifier signal closely matches the reference voltage, and the discrepancy is stored in memory. During normal operation, the stored compensation factor is applied to all output signals in order to maximize amplitude accuracy.

2.4 SYNTHESIZER OPERATING PRINCIPLES

The Model 3940 uses a digital direct type of synthesizer. This configuration yields more accurate, stable waveforms than is possible with conventional oscillators.

Figure 2-3 shows a simplified block diagram of the digital synthesizer address generator. The address generator is made up of a clock register, a binary adder, and the frequency setting register. The clock register counts clock pulses, and the frequency setting register stores frequency setting information. The binary adder adds the outputs of the clock register and the frequency setting register.

Initially, the frequency setting register is programmed with the binary value representing the programmed operating frequency, and the clock register is cleared (set to all 0s). The clock register counts clock pulses, and the address output increases value with time until the register overflows, at which point the register value returns to all

0s. The cycle starts again, and a ramp waveform shown in Figure 2-4 is generated. The slope of the ramp is directly proportional to the programmed frequency, and the repetition rate is inversely proportional to the set frequency.

The address output of the clock register is then applied to memory in which waveform data is stored, as shown in Figure 2-5. The output of the waveform memory is applied to the D/A converter, which converts the digital waveform data to an analog waveform.

In the Model 3940, the clock and frequency setting registers are both 40 bits wide. The clock has a frequency resolution of $2^{40} \times 10^{-4}$ Hz. As a result, the minimum frequency setting (when 0 ... 001₂ is loaded into the frequency setting register) is $2^{40} \times 10^{-4} / 2^{40} = 0.1$ mHz. Note that the address output uses the most significant 10 bits out of the 40 bits available, and a 10-bit D/A converter is used.

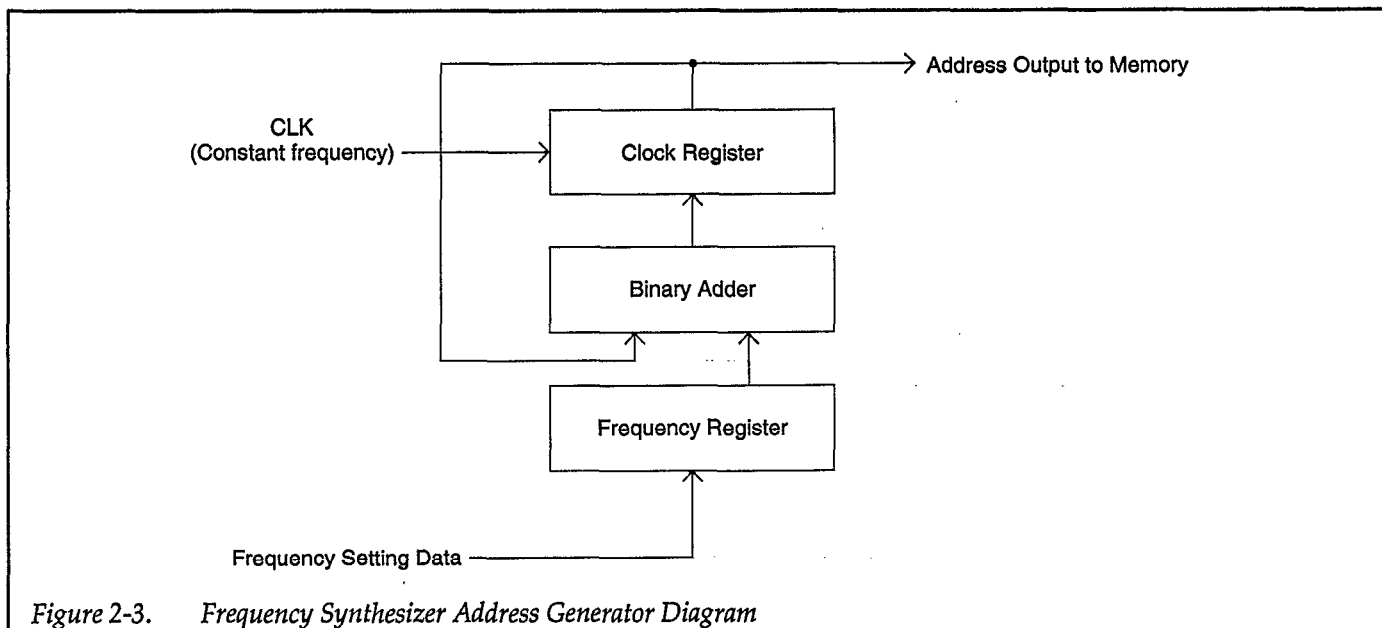

Figure 2-3. Frequency Synthesizer Address Generator Diagram

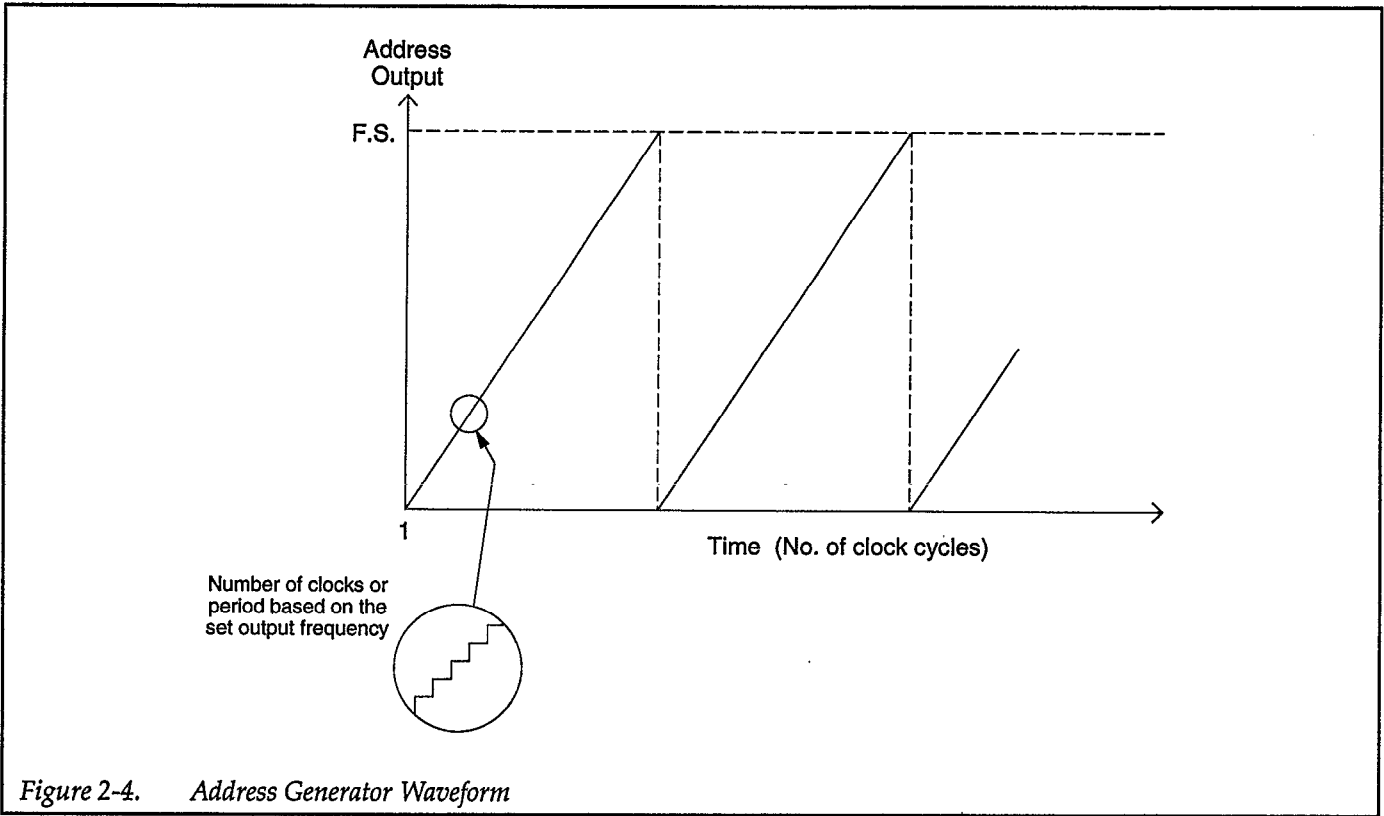

Figure 2-4. Address Generator Waveform

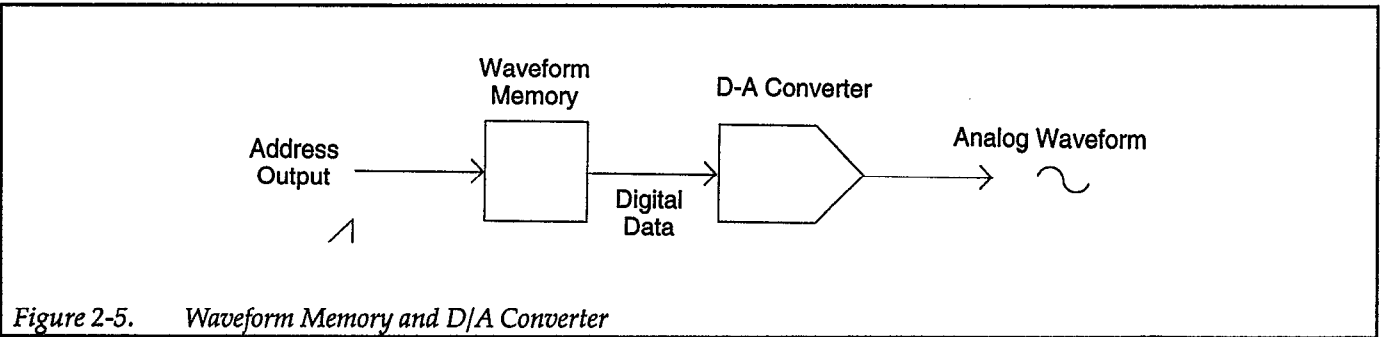

Figure 2-5. Waveform Memory and D/A Converter

SECTION 3

Service Information

3.1 INTRODUCTION

This section contains information on fuse replacement, instrument calibration and repair, and replacement parts for the Model 3940.

3.2 LINE FUSE REPLACEMENT

The line fuse, which is located on the rear panel, protects the power line input from excessive current. To replace the fuse, first unplug the line cord, then remove the fuse holder located immediately below the line receptacle. Replace the fuse only with the type recommended in Table 3-1. (A spare fuse is located inside the fuse holder.)

Table 3-1. Recommended Line Fuses

Line Voltage	Description	Keithley Part No.
100V/120V	2A, 250V, normal blow, 5mm x 20mm	FU-48
220V/240V	1A, 250V, normal blow, 5mm x 20mm	FU-96-2

WARNING

Disconnect the line cord and all other equipment from the instrument before replacing the line fuse.

CAUTION

Using the wrong fuse type may result in instrument damage.

3.3 CALIBRATION

The following paragraphs give step-by-step procedures for calibrating the Model 3940. This calibration procedure can be performed at specified intervals, or if the performance verification procedures covered in Section 1 show that instrument performance is not within specifications.

NOTE

Calibration must be performed in the sequence covered below. If any of the calibration procedures cannot be performed successfully, refer to the repair information in paragraph 3.6 unless the unit is still under warranty. (Units still under warranty should be returned to the factory or authorized repair facility for repair.)

3.3.1 Environmental Conditions

Calibration should be performed at 18-28°C (68-82°F) and at less than 70% relative humidity.

3.3.2 Initial Conditions

The Model 3940 and the test equipment should be turned on and allowed to warm up for one hour before calibration. If the instrument has been subjected to extreme temperature or humidity, allow additional time for stabilization.

3.3.3 Line Power

Before calibrating the instrument, be sure the rear panel line voltage is set to the correct operating voltage. The Model 3940 should be calibrated while operating at a line voltage within 10% of the line voltage switch setting and at a line frequency from 48Hz to 62Hz.

3.3.4 Recommended Calibration Equipment

Table 3-2 summarizes recommended equipment for calibrating the Model 3940. Similar equipment may be used as long as corresponding specifications are comparable.

3.3.5 Cover Removal

Before calibration, the top and bottom covers must be removed as covered below (see Figure 3-1).

WARNING

Potentially hazardous voltages may be present inside the instrument. Use caution when performing calibration.

CAUTION

A conductive coating is applied to the inner surface of the covers. Be careful not to scratch the coating when removing the covers. Also be careful not to peel off the corners of the polyester film covering the front panel; the film can be peeled off relatively easily.

1. Place the instrument upside down on a soft cloth or rubber mat to avoid scratching the top cover.
2. Remove the four corner screws that secure the bottom cover, then remove the cover.
3. Place the instrument right side up.
4. Remove the top cover by separating it from the chassis.

Table 3-2. Recommended Test Equipment for Calibration

Manufacturer	Model	Description	Specifications
Keithley	197A	DMM (DC volts, AC volts) (5-1/2 digits)	20V range; +(0.015% of rdg + 3 counts) ACV; ±(0.35% of rdg + 100 counts)
Philips	PM6654C PM9678	Timer/Counter TCXO option	0.01Hz-120MHz; time base aging <math><1 \times 10^{-7}</math>/month; Vp-p measurements
Keithley	7051-2	BNC Interconnect Cable	50Ω coaxial cable (RG-58C), male BNC connectors, 2ft. (0.6m)
Keithley	1681	Clip-on Test Lead Clip Set	Banana/Clip Test Leads
Pomona	1468	BNC-banana Adapter	Female BNC connector to double banana plug

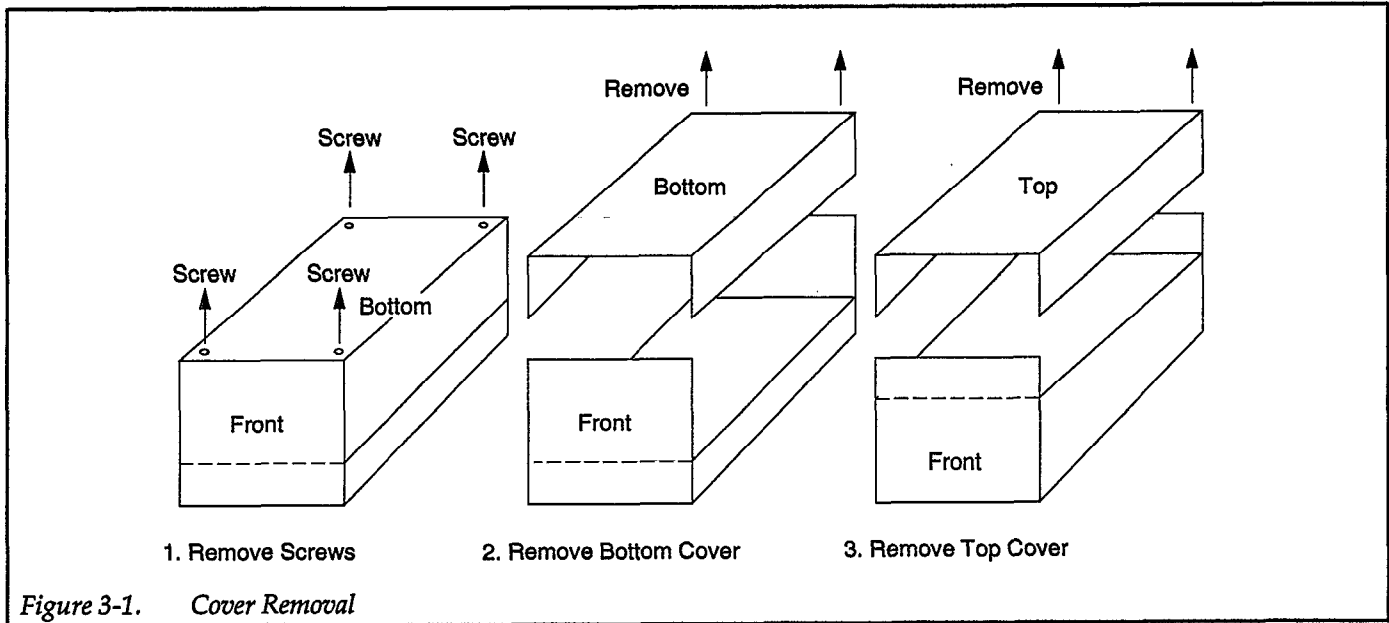

3.3.6 Calibration Adjustments

Analog board calibration adjustments are shown in Figure 3-2, and control board calibration adjustments are shown in Figure 3-3.

NOTE

It is not necessary to remove the analog board to gain access to control board calibration adjustments. Control board calibration adjustments are accessible from the side of the board.

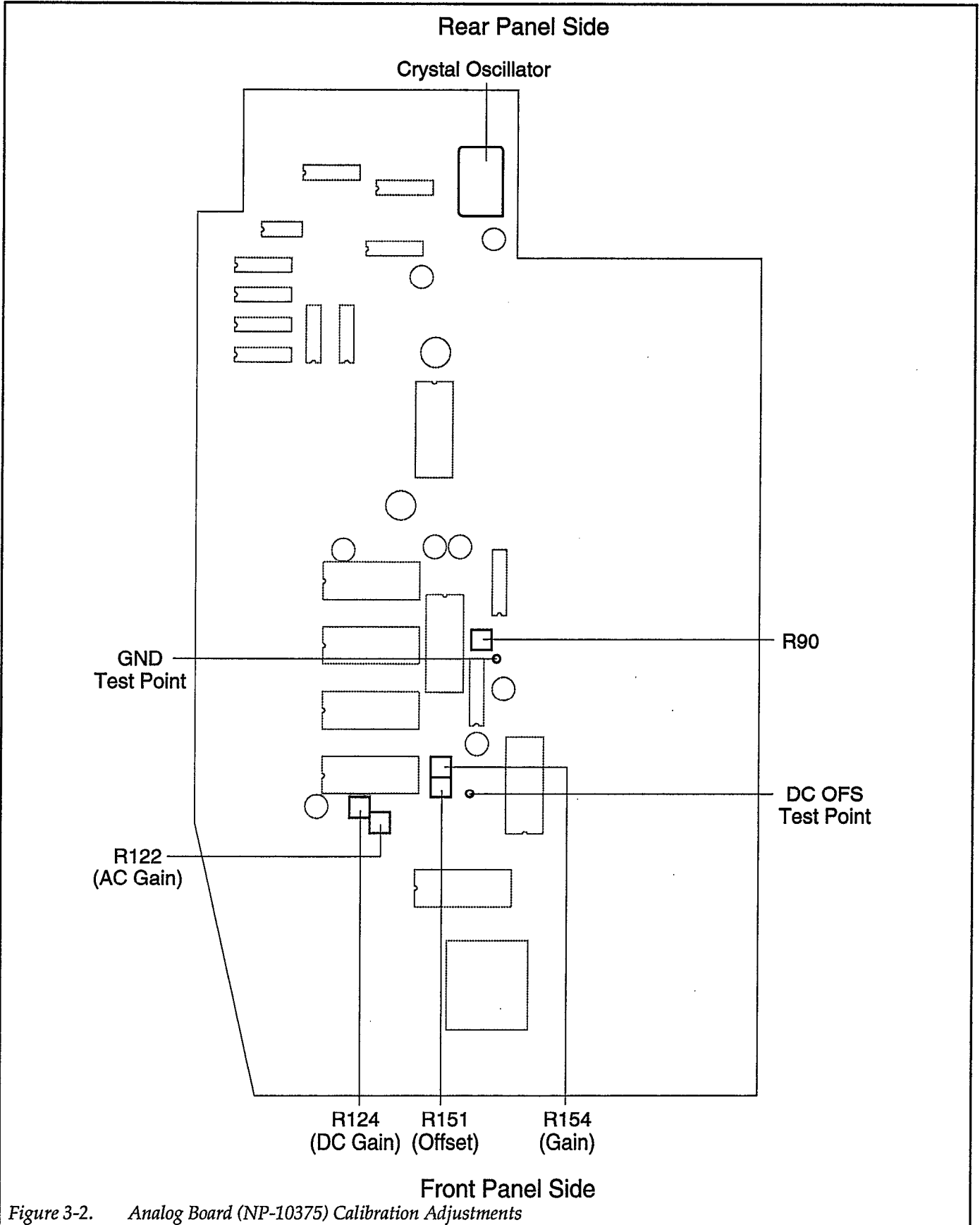

Figure 3-2. Analog Board (NP-10375) Calibration Adjustments

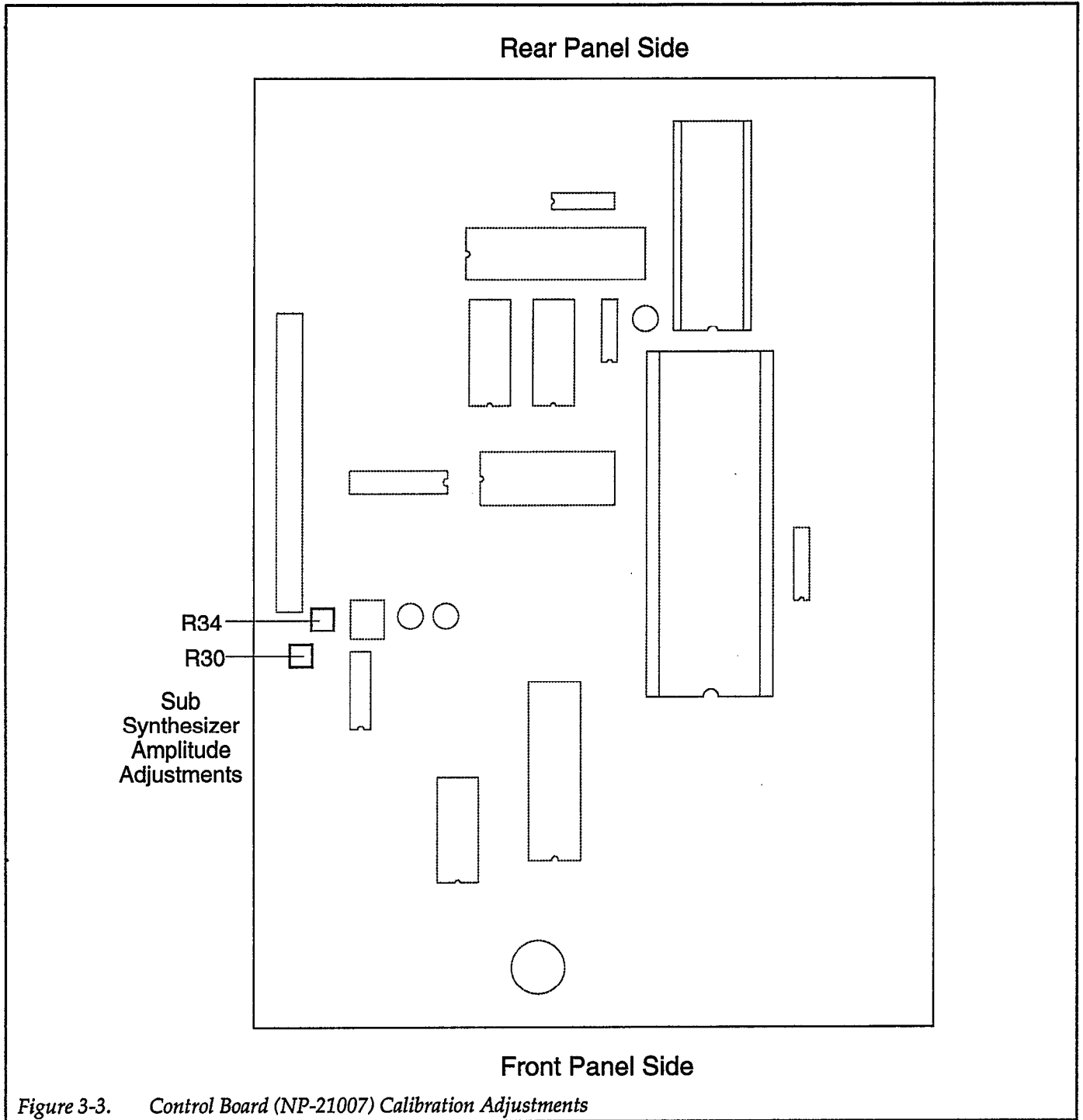

Figure 3-3. Control Board (NP-21007) Calibration Adjustments

3.3.7 Calibration Procedures

Sub Synthesizer Amplitude Accuracy

1. Connect the Model 197A DMM to the Model 3940 sub synthesizer FCTN OUT jack, as shown in Figure 3-4.
2. Set the Model 197A to the DCV function, and enable auto-ranging.
3. Setup the Model 3940 as follows:
Factory Default (press SHIFT PRST)
SUB FCTN: \square
SUB AMPTD: 20Vp-p
SUB FREQ: 0.2Hz
MODIFY cursor position: 0.2 Hz

NOTE

Turning the MODIFY knob counter-clockwise with these settings will result in a frequency of 0Hz, allowing you to stop oscillation at a positive or negative voltage, as required for the following steps.

4. When the output voltage is negative, adjust R34 for a DMM reading of $-10.000V \pm 0.001V$.
5. When the output voltage is positive, adjust R30 for a DMM reading about half way between the present DMM reading and $+10.000V$. For example, if the DMM now reads $+9.8V$, adjust R30 for a new DMM reading of $+9.9V$.
6. Repeat steps 4 and 5 until the two DMM readings are $+10.000V \pm 0.001V$ and $-10.000V \pm 0.001V$.

Frequency Accuracy

1. Connect the PM 6654C Timer/Counter to the Model 3940 main synthesizer FCTN OUT jack, as shown in Figure 3-5.
2. Set the timer/counter to measure a frequency of 10MHz.
3. Setup the Model 3940 as follows:
Factory Default (press SHIFT PRST)
FREQ: 10MHz
AMPTD: 20Vp-p/OPEN
4. Adjust the crystal oscillator trimmer for a timer/counter reading of 9.99999MHz to 10.00001MHz.

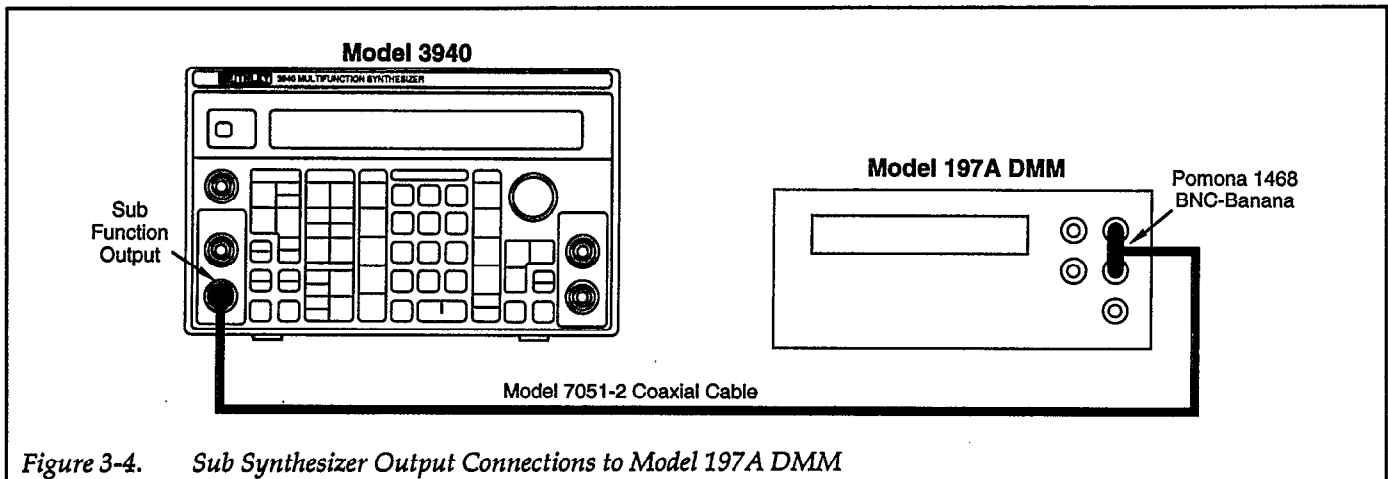
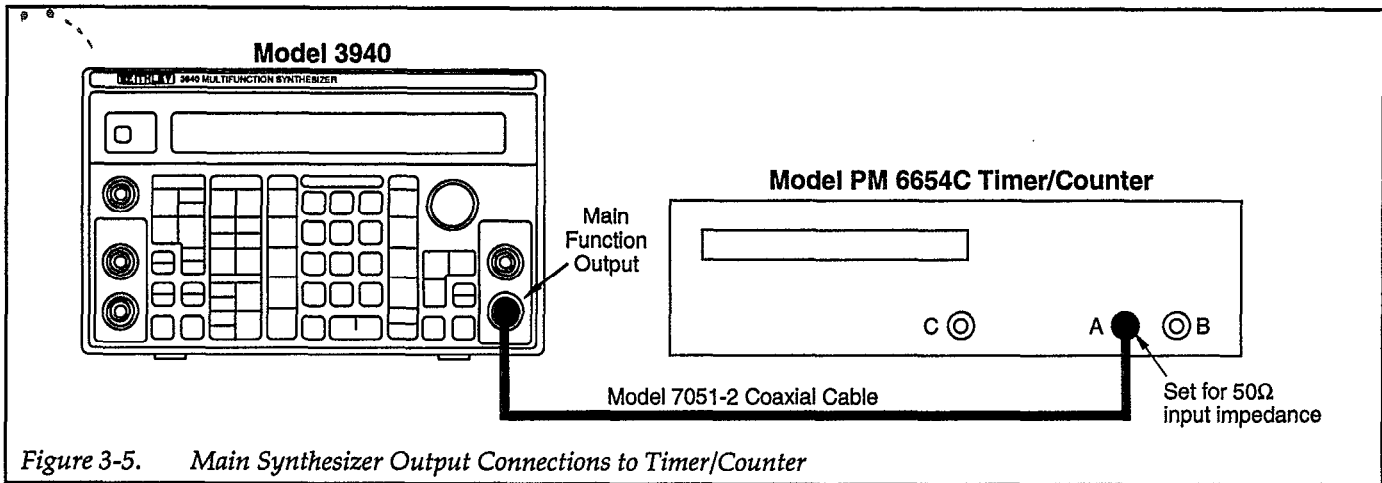
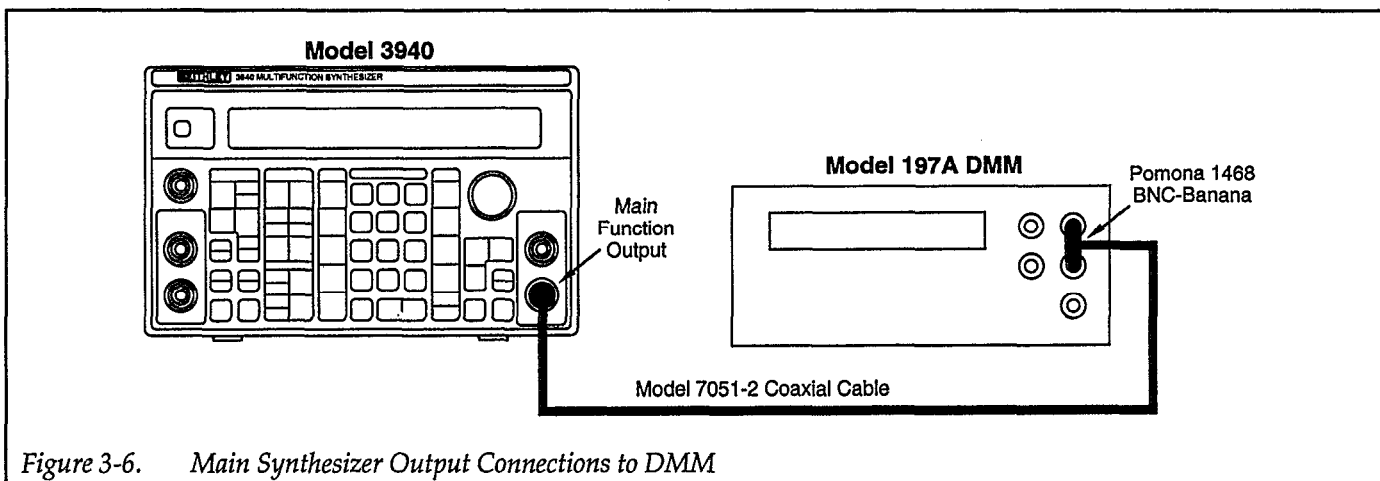

Figure 3-4. Sub Synthesizer Output Connections to Model 197A DMM



Main Synthesizer Amplitude Accuracy

1. Connect the main synthesizer FCTN OUT jack to the DMM, as shown in Figure 3-6.
2. Set the DMM to the ACV function, and select auto-ranging.
3. Setup the Model 3940 as follows:
Factory Default (Press SHIFT PRST)
FCTN: SIN
AMPTD: 20Vp-p
4. Adjust R122 (AC GAIN) for a DMM reading of 7.07V ±1mV.
5. Using banana plug to clips test leads, connect the DMM to the DC OFS and GND terminals of the analog board (NP-10375), as shown in Figure 3-7.
6. Set the DMM to the DCV function and auto-ranging.
7. Setup the Model 3940 as follows:
Factory Default (press SHIFT PRST)
FCTN: DC
OFFSET: +10.0V
8. Adjust R151 (OFFSET) for a DMM reading of -9.920V ±1mV.
9. Setup the Model 3940 as follows:
OFFSET: -10.0V
10. Adjust R154 (GAIN) for a DMM reading of +9.920V ±1mV.
11. Repeat steps 7 through 10 until both readings are within ±1mV of the required values.



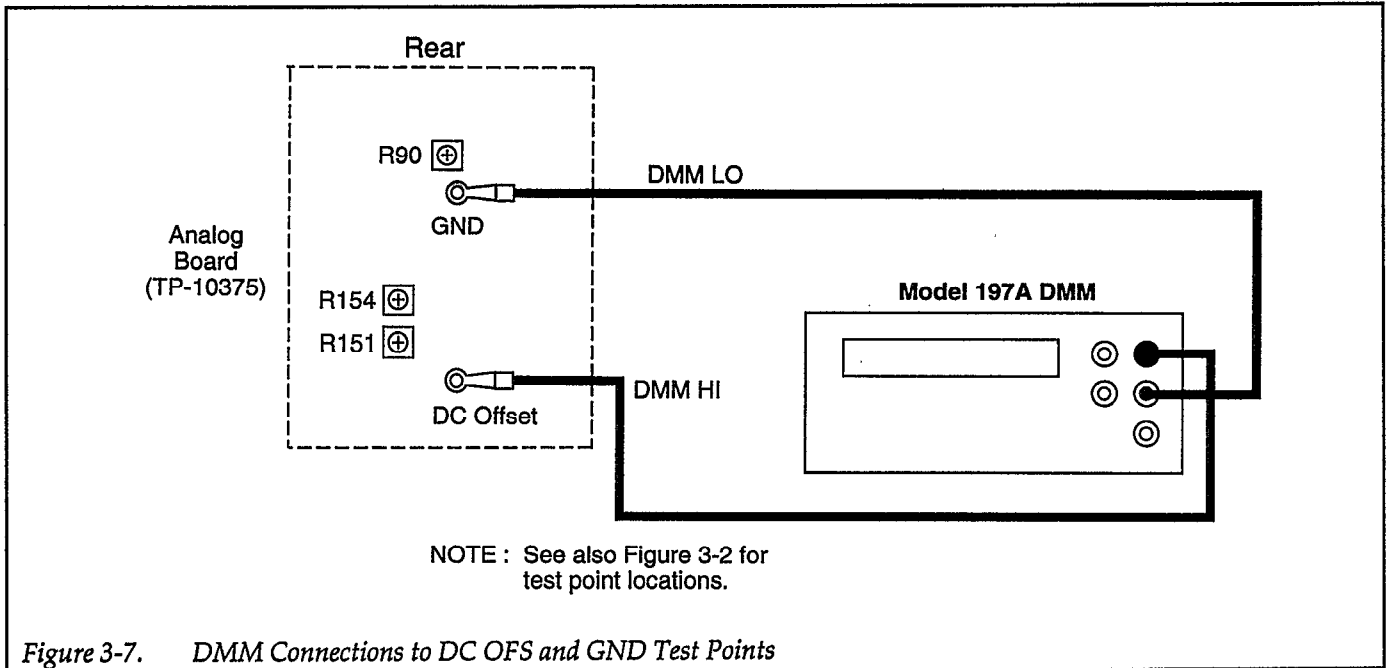

Main Synthesizer DC Offset Accuracy

1. Connect the main synthesizer FCTN OUT jack to the DMM (Figure 3-6).
2. Select the DCV function and auto-ranging on the DMM.
3. Press the CAL key to execute front panel calibration.

NOTE

Perform the following steps as soon as possible after the front panel calibration cycle is complete.

4. Set the OFFSET to +10V, then wait 30 seconds for the reading to settle. Adjust R124 (DC OFFSET) for a DMM reading of $+10.000V \pm 2mV$.
5. Set the OFFSET to -10V, then wait 30 seconds for the reading to settle. Adjust R124 (DC OFFSET) so that the deviation in the DMM reading from -10.000V is exactly half its former value to within 2mV. For example, if the reading before adjustment is -9.8V, adjust R124 for a reading of $-9.9V \pm 2mV$.
6. Set the OFFSET to +10V, then verify that the DMM reading is $+10V \pm 15mV$. If not repeat steps 3 and 4.
7. Toggle the OFFSET voltage between -10V and +10V, and verify that the DMM readings are both within 15mV of -10V or +10V, and that the deviations are of the same polarity. Note that this adjustment may be

difficult to set and may require a number of tries to set properly.

Square Wave Duty Cycle

1. Connect the Model 3940 main synthesizer FCTN OUT jack to the Model PN 6654C Timer/Counter (Figure 3-5).
2. Set the counter to measure the pulse width of input A.
3. Setup the Model 3940 as follows:
Factory Default (press SHIFT PRST)
FREQ: 500kHz
AMPTD: 12.5Vp-p
FCTN: \square
4. Adjust R90 for a timer/counter reading of $1\mu\text{sec} \pm 0.02\mu\text{sec}$.

3.3.8 Cover Replacement

After calibration, replace the top and bottom covers, and secure them with the four screws removed earlier. Be careful not to scratch the conductive coating applied to the inside of the covers, and be sure not to peel off the front panel polyester film.

3.4 FAN FILTER CLEANING

The fan filter should be cleaned at least once every three months when the instrument is operated in a clean environment or at least once a month when the instrument is operated in a dirty environment. The fan filter element should be cleaned as follows:

1. Turn off the instrument power and disconnect the line cord.
2. Snap off the filter cover from the fan on the rear panel.
3. Remove the filter element from the filter cover.
4. Soak the filter element in a solution of mild detergent and water until clean.
5. Rinse the filter element thoroughly in clean water, then allow the filter to dry thoroughly before replacement.
6. When the filter has dried completely, install it in the filter cover, then replace the cover/filter assembly on the fan.

CAUTION

The instrument should not be operated without the filter in place.

3.5 RECHARGEABLE BATTERY REPLACEMENT

The rechargeable battery, which backs up setup RAM, does not normally require field replacement. However, if you notice the instrument no longer stores setups even after charging the battery, the battery is probably defective and should be replaced. Follow the steps below to replace the battery.

CAUTION

Many parts on the internal circuit boards are static sensitive. To avoid possible damage, perform any repair operations only at a properly grounded work station, and use only grounded-tip soldering irons and anti-static de-soldering tools.

NOTE

Because of the relative difficulty of the repair, it is recommended that the Model 3940 be returned to the factory or authorized repair facility for rechargeable battery replacement.

1. Disconnect the line cord and all other instruments from the Model 3940.
2. Remove the top and bottom covers (refer to paragraph 3.3.5 for procedure).
3. Note the positions of the various cables connected to the analog board, then disconnect all cables from the board.
4. Remove the screws that secure the analog board to the chassis, then remove the analog board.
5. Remove the control board in a similar manner by releasing the standoff clips that secure the board to the chassis.
6. Unsolder the battery leads, and cut the sealant that secures the battery. Remove the battery.
7. Install a new battery, taking care to observe polarity.
8. After soldering, secure the battery to the board using an electronics-approved silicone or RTV sealer.
9. Install the control board and analog board, and connect all cables to the boards.
10. Replace the covers.
11. Turn on the power for 50 hours to fully charge the new battery.

3.6 REPAIR

Instrument repair may necessary in cases where the instrument does not meet the requirements of the operation check (Section 1) and is probably required if the unit cannot be properly calibrated.

3.6.1 Factory Service

If the Model 3940 is still under warranty, it is recommended that the unit be returned to the factory or Keithley authorized repair facility for repair or calibration. When returning the unit for service, include the following:

- Complete the service form at the back of this manual.
- Advise as to the warranty status of the instrument.
- Write the following on the shipping label: ATTENTION REPAIR DEPARTMENT.

3.6.2 Power Supply Test Points

Figure 3-8 shows power supply test point locations on the analog board.

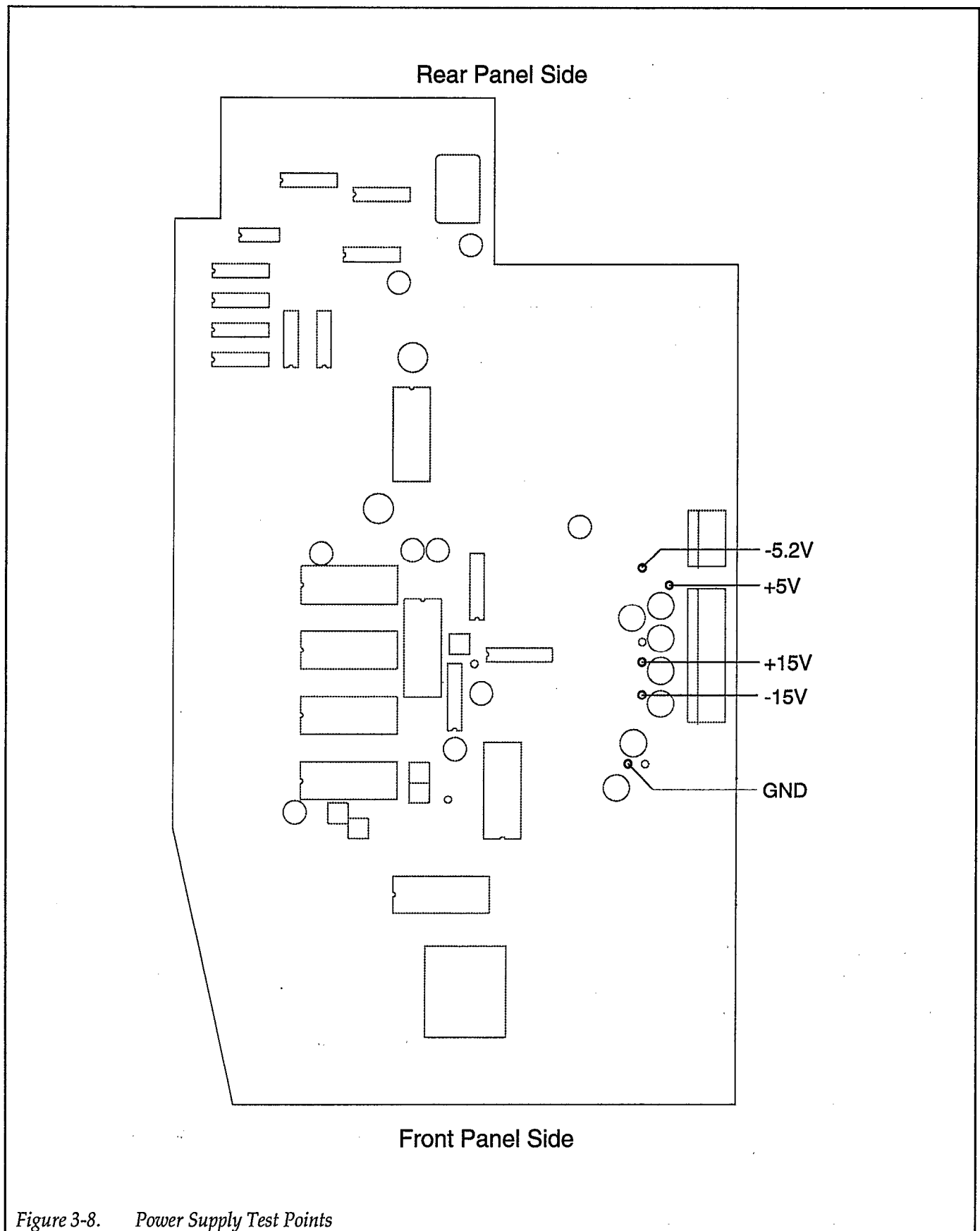

Figure 3-8. Power Supply Test Points

3.6.3 Board-Level Repair

Table 3-3 summarizes which circuit board is most likely at fault for various problems. Paragraph 3.7 lists replacement boards and certain other parts. If board replacement fails to fix the problem, the most likely cause of the fault is the wiring between the boards.

Table 3-3. Board Level Repair Summary

Problem	Probable Cause
1. MODIFY function	A
2. FCTN OUT ON/OFF function	A or B
3. MODE (TRIG) function	A or B
4. SWEEP function	A
5. EXT ADD function	B
6. Synchronous operation	A or B
7. Square wave rise/fall time	A or B

A: Control circuit board (NP-21007)

B: Analog circuit board (NP-10375)

3.7 REPLACEABLE PARTS

3.7.1 Parts List

Table 3-4 summarizes available Model 3940 replacement parts. Figure 3-9 shows the location of mechanical parts.

3.7.2 Ordering Parts

To order a part, or to obtain information on replacement parts, contact your Keithley representative or the factory. When ordering parts, include the following information:

- Instrument model number
- Instrument serial number
- Keithley part number
- Part description

Table 3-4. Replaceable Parts

Description	Part Number	Qty.
Analog Board (NP-10375)	080-33692-00	1
Control Board (NP-21007)	080-33706-00	1
Switching power supply	100-20462-00	1
Fan	300-00751-00	1
LCD	304-10118-00	1
EL back light	100-70028-00	1
Noise filter (AC receptacle)	240-03212-00	1
BNC Connector (rear panel)	310-00169-00	6
BNC connector (front panel)	310-00347-00	5
Power switch (internal)	332-19141-00	1
Power switch (on front panel)	332-19133-00	1
Flexible wire (for power switch)	332-19150-00	1
Button (for power switch)	359-03554-00	1
Voltage selecting switch	332-50057-00	1
Rotary encoder	332-90041-00	1
Power Transformer (for 3940)	244-19435-00	1
Ground terminal	330-05389-00	1
Cable assembly (for GPIB)	352-07540-01	1
Switch spacer (for power switch)	520-05356-00	1
Collar (for LCD)	606-02236-00	4
BNC bushing	446-00046-00	5
BNC spacer	540-00157-00	5
Knob (for rotary encoder)	486-24060-00	1
Rear panel	400-11682-00	1
Heat sink	533-00351-00	1
Transistor holder	526-07216-00	1
Hexagonal stud	606-00284-00	6
Spring (for heat sink)	536-0029-00	3
Hexagonal spacer (for power switch)	606-01426-00	2
Spacer (for rotary encoder)	520-05976-00	1
Grommet	546-00146-00	1
Air filter	459-00183-00	1
Rear filter	526-12848-00	1
Standoff	529-00118-00	10
Fuse (100V/120V)	FU-48	1
Fuse (220V/240V)	FU-96-2	1
Battery (Rechargeable)	*	1

*Part number not available at time of printing. Contact Repair Department.

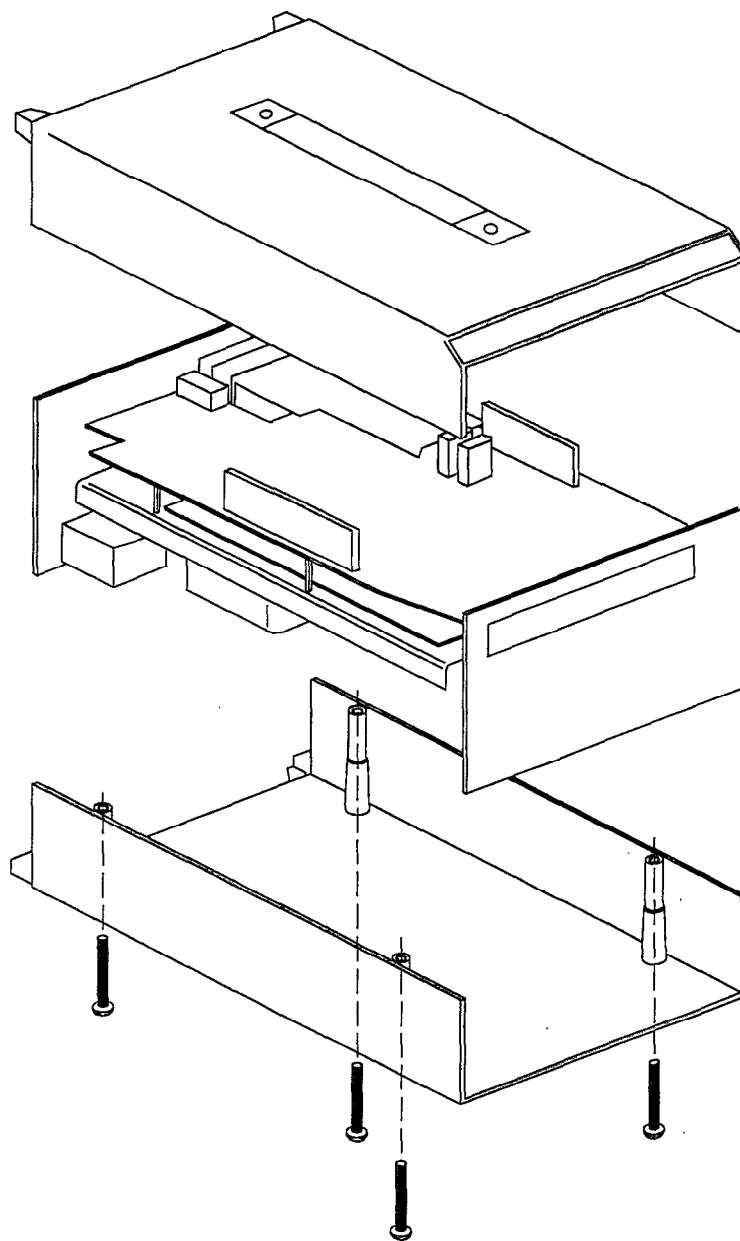

Figure 3-9. Model 3940 Exploded View

APPENDIX A

Typical Data

INTRODUCTION

Appendix A provides the typical performance data for the Model 3940.

This instrument was thoroughly tested and inspected

and certified as meeting its published specifications when it was shipped from the factory. However, the typical data represents mean values of measurements for each Model 3940. Thus, measured performance of your Model 3940 may be different than that indicated by the typical data curves shown here.

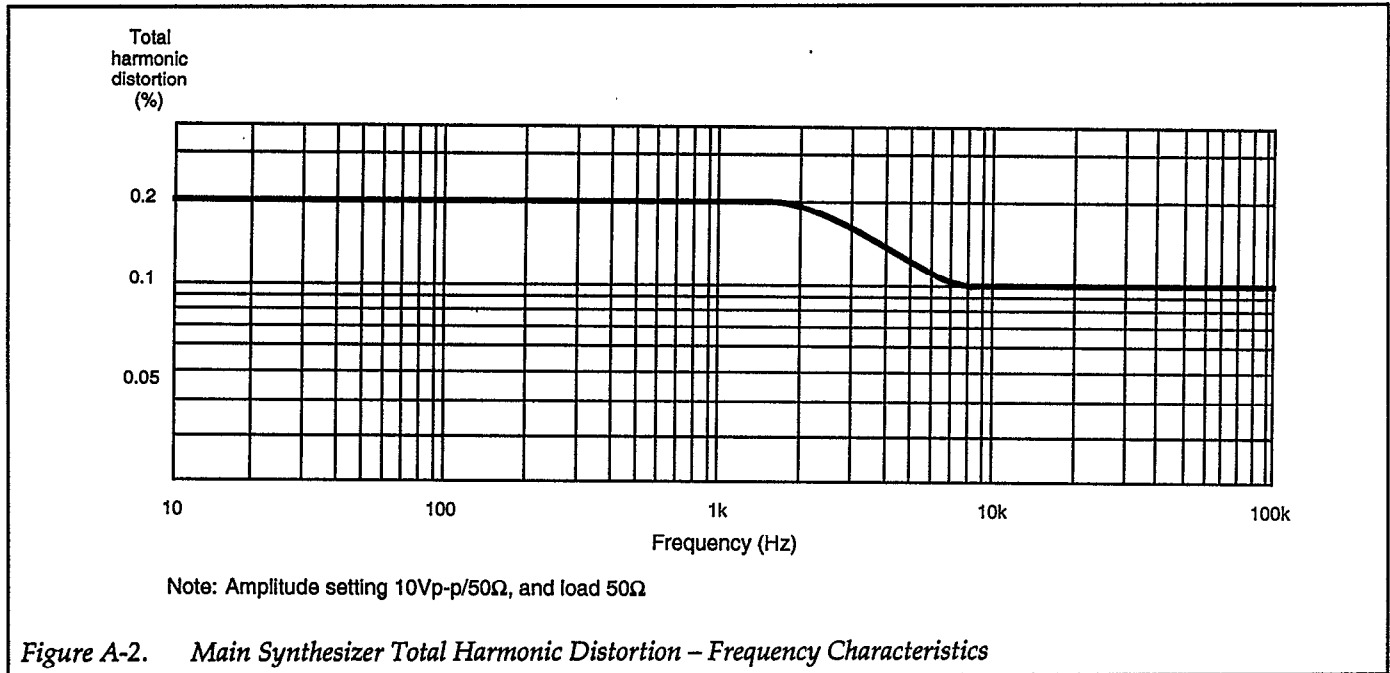
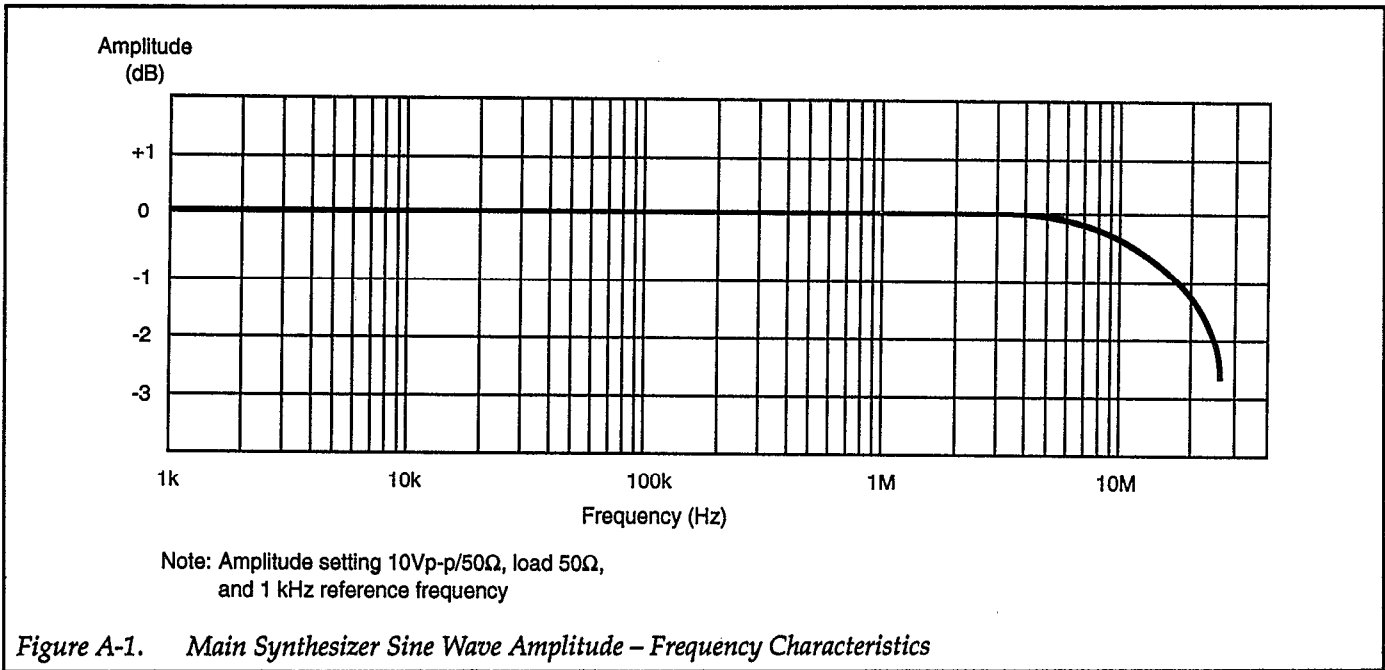

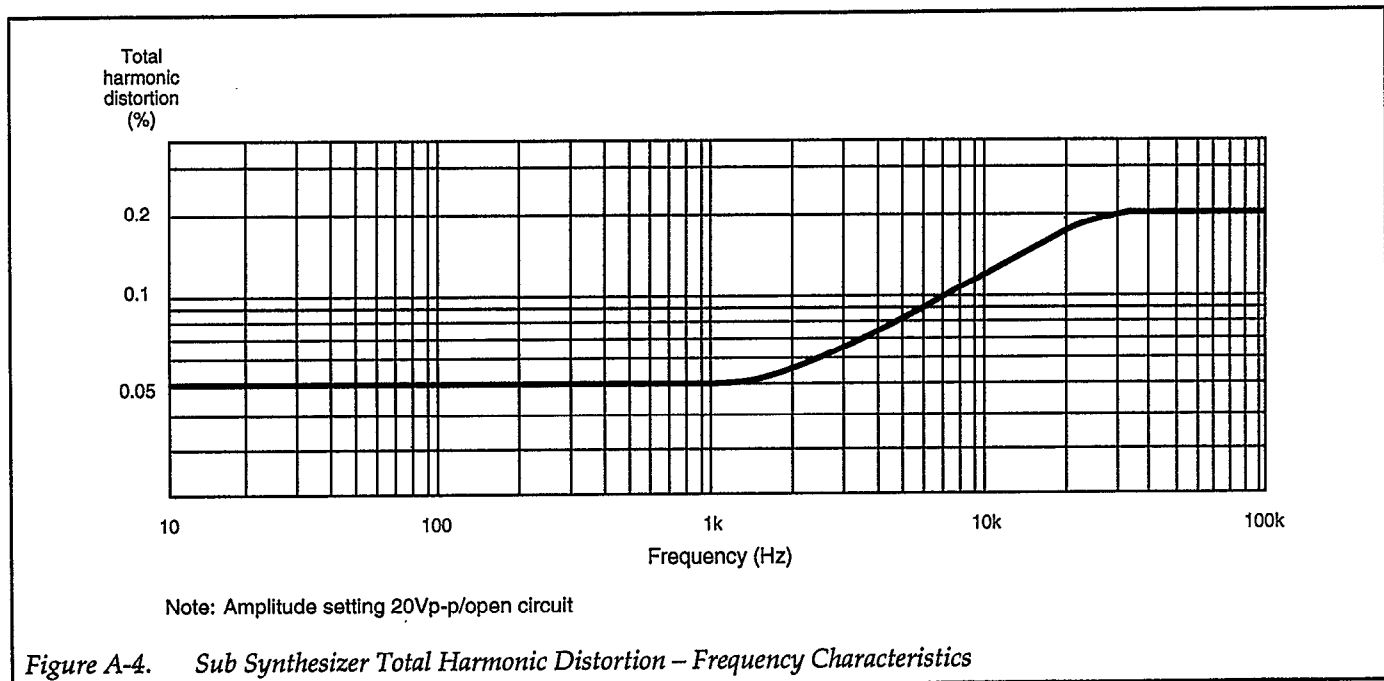
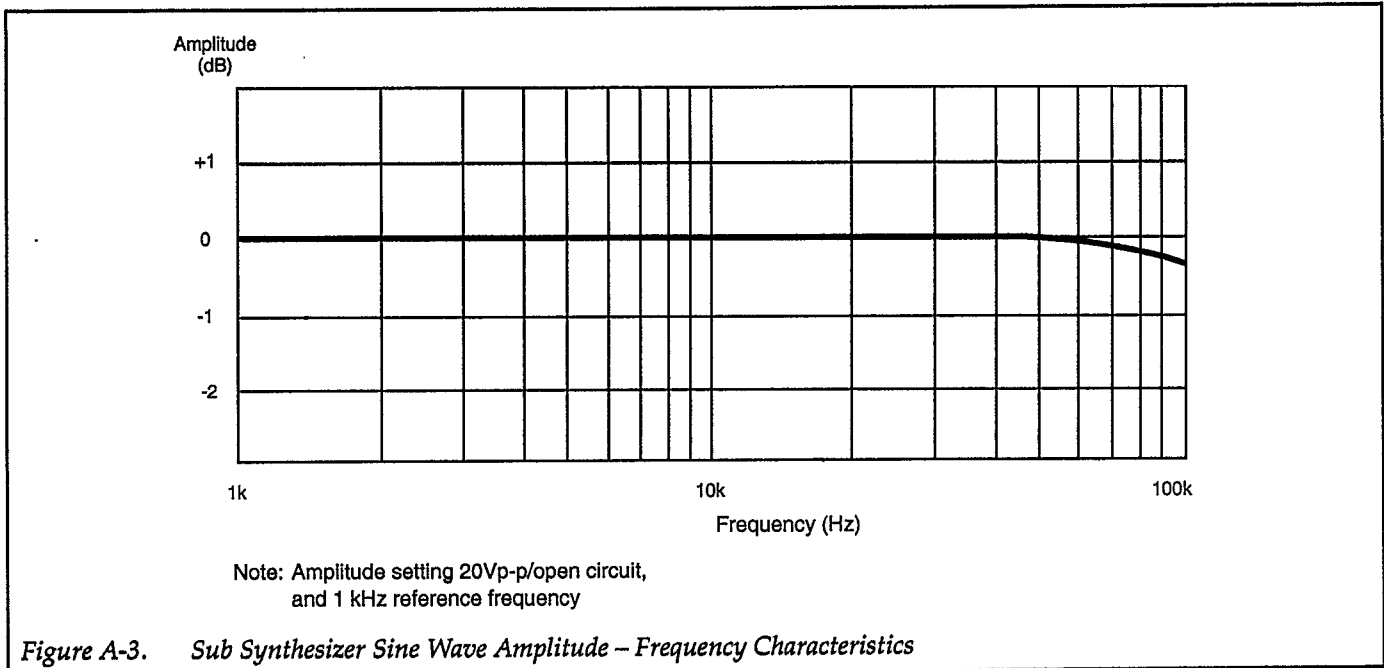

APPENDIX B

Model 3940 Specifications

B.1 ELECTRICAL SPECIFICATIONS

(Note: Items which are not denoted refer to the specifications of the main synthesizer.)

Waveforms		
Types	DC only, \sim , \square , \sphericalangle , \sphericalangle , \sphericalangle , ARB	
ARB Waveform Input	Input	Data input with GPIB
	Address	0000 to 1023
	Data	-511 to +511









Oscillation Modes		
Continuous	CONT	Continuous oscillation
Burst	BRST	Repeating mark wave cycle (oscillation) and space wave cycle (stop) Mark wave cycle: 0.5 to 32768.0 (0.5 cycle resolution) Space wave cycle: 0.5 to 32768.0 (0.5 cycle resolution)
Trigger	TRIG	Mark wave cycle oscillation by trigger signals Mark wave cycle: 0.5 to 32768.0 (0.5 cycle resolution)
Gate	GATE	Oscillates in units of half cycles while trigger signal is ON.

Stop Level
HOLD: Stops at oscillation start phase. RESET: Stops at center value of the waveform. (Not applicable in CONT mode)

Frequency					
Frequency Range	Condition		General Specifications		
	Oscillation Modes, Stop Level	Waveforms	Specifications	Setting Range	
	CONT	\sim , Duty cycle is fixed at 50% \square	0 to 20MHz	0 to 25MHz	
		Duty cycle is variable \square	0 to 1MHz	0 to 1MHz	
		Other waveforms	0 to 1MHz	0 to 25MHz	
	BRST, TRIG, GATE	HOLD	\sim , Duty cycle is fixed at 50% \square	0 to 10MHz	0 to 10MHz
			Duty cycle is variable \square	0 to 1MHz	0 to 1MHz
			Other waveforms	0 to 1MHz	0 to 10MHz
		RESET	All waveforms	0 to 1MHz	0 to 1MHz
	However, continuous output of the entire data of the ARB waveform is possible up to approximately 107kHz.				
	Display	Max. 12 digits, resolution 0.1mHz (fixed)			
Accuracy	$\pm 5 \times 10^{-6}$ (± 5 ppm) (at 20°C to 30°C)				
Temperature Coefficient	$\pm 0.5 \times 10^{-6}$ / C typ. (± 0.5 ppm/C typ.)				
Stability	(24 hours after power on) $\pm 5 \times 10^{-6}$ /year (± 5 ppm/year)				
Setting in terms of period	Range	40ns to 10,000s			
	Display	Max. 6 digits, minimum resolution 1ns			
		Oscillates at a frequency that is reciprocal of the set period (digits smaller than 0.1mHz are truncated).			

Specifications subject to change without notice.

ELECTRICAL SPECIFICATIONS (CONT.)

Output Characteristics					
Maximum Output	AC only	20Vp-p/open, 10Vp-p/50Ω			
	DC only	±10V/open, ±5V/50Ω			
Display	Display switchable between open circuit voltage (/OPEN) and voltage into 50Ω load (/50Ω). However, for dBm, value displayed is always for a 50Ω load (/50Ω). For an arbitrary waveform the units are always Vp-p and the displayed voltage corresponds to the data values -511 and +511.				
	AC	Vp-p	Max. 3 digits	Minimum Resolution	0.01mVp-p/open 0.01mVp-p/50Ω
		Vrms	Max. 3 digits		0.01mVrms/open 0.01mVrms/50Ω
		dBV	Max. 3 digits and minus sign		0.1dBV/open 0.1dBV/50Ω
		dBm	Max. 3 digits and minus sign		0.1dBm/50Ω
DC	Max. 3 digits and minus sign		0.1mV/open 0.1mV/50Ω		
AC amplitude range for 0V DC offset		See Table B-1.			
AC amplitude resolution and accuracy for 0V DC offset		See Table B-2.			
Voltage range, resolution, and accuracy for DC only		See Table B-3.			
Minimum AC amplitude, resolution, and DC voltage accuracy for AC + DC		See Table B-4.			
Amplitude Frequency Characteristics	In CONT mode, 1kHz reference frequency, 0V DC offset, 50Ω load, and amplitude setting of 100mVp-p to 10Vp-p for waveforms other than  . (rms amplitude for  .)				
		Up to 1MHz 1MHz to 7MHz 7MHz to 10MHz 10MHz to 20MHz	+0.3dB (RMS) +0.3, -0.5dB (RMS) +0.3, -1.0dB (RMS) +0.3, -2.5dB (RMS)		
	 (At duty cycle fixed/variable 50%)	Up to 1MHz	±3% (p-p)		
		Up to 100kHz	±3% (p-p)		
		Up to 100kHz	±5% (p-p)		
 Spectrum purity	In CONT mode, 0V DC offset, 50Ω load, and 10.0Vp-p amplitude setting				
	Total Harmonic Distortion	10Hz to 100kHz	0.3% max		
	Harmonics	100kHz to 20MHz	-35dBc max		
	Spurious	up to 20MHz	-40dBc max		
 Waveform Characteristics	50Ω load, 0V DC offset and 100mVp-p amplitude setting				
	Risetime, falltime	8ns max (15ns max in modes other than CONT mode, when stop level is RESET)			
	Overshoot, undershoot	5% max of output p-p amplitude			
	Duty cycle	(Not during sweep in CONT mode)			
		Accuracy for fixed duty cycle (50%)	up to 100kHz	±0.3% of period	
100kHz to 1MHz			±2% of period		
Variable	Range	5.0% to 95.0% (resolution 0.1%)			
	Accuracy	±1% of period (up to 1MHz), jitter 15ns max			
Output impedance	50Ω, unbalance				
Connector	BNC receptacle on front panel				

ELECTRICAL SPECIFICATIONS (CONT.)

Sync Output	
Output Voltage	TTL Level
Output impedance	Approximately 50Ω, unbalanced
Connector	BNC receptacle on front panel

Gate/Trigger Oscillation		
Trigger source	INT (internal)	Synchronizes with sub synthesizer output (positive/negative logic), manual triggering from front panel key, or remote triggering through GPIB
External trigger input	EXT (external)	Synchronized through external trigger input terminal (positive/negative logic), manual triggering from front panel key, or remote triggering through GPIB
	Input voltage	TTL Level (Input to 74LS14, pulled up by 4.7kΩ)
	Minimum pulse width	50ns
	Connector	BNC receptacle on front panel
Trigger delay	200ns max from external trigger input to waveform output 100ns max from sub synthesizer SYNC OUT to waveform output	
Trigger jitter	50ns max	

External Add Input			
(An external signal input is added (summed) to main synthesizer waveform output).			
Gain of External Add Input	Total set ¹ Voltage (Peak)	Gain ² (/OPEN)	Gain ³ (/50Ω)
	1V to 10V	1	1/2
	100mV to 1V	1/10	1/20
	100mV to 10mV	1/100	1/200
	1mV to 10mV	1/1000	1/2000
Maximum External Input (V _{peak}) = 10 - Total Set Voltage/Gain			
$^1 \text{ Total Set Voltage} = \frac{\text{Set AC Amplitude (V}_{p-p})}{2} + \text{Set DC Voltage (V)} $			
Total Set Voltage = Set DC Voltage (V) when waveform is DC.			
$^2 \text{ Gain} = \frac{\text{Main synthesizer output signal value}}{\text{External Add Input Signal value}}$			
³ Gain is 1/2 of the /OPEN value with a 50Ω load (/50Ω)			
Input impedance	Approx. 100kΩ		
Frequency range	DC to 1MHz		
Connector	BNC receptacle on rear panel		

Phase	
Range	-360° to 360°
Display	Max. 4 digits and minus sign, resolution 0.1 (fixed)
Oscillation start phase for burst/trigger/gate oscillation	
Oscillation will restart at this phase when the φ SYNC key is pressed or when the GPIB "SYN" command is given during independent or master operation.	
In addition, slave unit oscillation will restart at this phase when the φ SYNC key of the master unit is pressed or when the GPIB "SYN" command is given.	

ELECTRICAL SPECIFICATIONS (CONT.)

Synchronous Operation			
The synchronous operation mode can be selected by connecting the optional cable to PHASE SYNC I/O of multiple units. The master unit can control up to 3 slave units.			
Synchronous Operation Mode	Mode	Operation	PHASE SYNC I/O connections
	Single	Single unit operation	No connection
	Master	Transmit clock and ϕ SYNC pulse to slave unit	Connect with the optional synchronous cable (master connector).
	Slave	Operate with clock and ϕ SYNC pulse from the master unit	Connect with the optional synchronous cable (slave connector).
ϕ SYNC	Generates ϕ SYNC pulse to the PHASE SYNC I/O connector simultaneously when restarting oscillation of both main synthesizer and sub synthesizer during CONT mode.		
Clock and ϕ SYNC pulse delay time/unit		10ns max/unit	
Delay time from ϕ SYNC pulse to waveform output	Main synthesizer	\sim , \square (duty cycle fixed/variable 50%)	120ns max
		Other waveforms	80ns max
		Jitter	15ns max
	Sub synthesizer	\sim	3 μ s max
Other waveforms		2 μ s max	
Jitter		350ns max	
PHASE SYNC I/O connector	36-pin connector on rear panel		

ELECTRICAL SPECIFICATIONS (CONT.)

Frequency Sweep					
Sweep mode	Sweep functions		CONT (continuous sweep)	SINGL (single sweep)	
			┌ or ┐	┌ or ┐	
	LIN	∧	∧ or ∨	/ or \	
		∨	∨ or /	∧ or ∨	
	LOG	∧	∧ or ∨	/ or \	
∨		∨ or /	∧ or ∨		
Sweep range	Upper limit		Identical to ordinary oscillation		
	Lower limit	┌, LIN	0Hz		
		LOG	10.0mHz		
Minimum sweep width	┌, LIN		0.1mHz		
	LOG		1 octave (2 times)		
Sweep time	Range		5ms to 9999s		
	Display		Maximum 4 digits, minimum resolution 1ms		
Range setting		By setting start/stop frequencies or center/span frequencies			
Control	SINGL START		Starts single sweep		
	CONT START		Starts continuous sweep		
	SWEEP OFF		Halts sweep		
	START STATE		Sets output to the start frequency output state		
	STOP STATE		Sets output to the stop frequency output state.		
	HOLD/RESM		Holds and resumes sweep		
Other functions		Set marker frequency and substitute of marker frequency to center frequency			
Input	Single start input	Input voltage		TTL Level (Input of 74LS14 is pulled up by 4.7kΩ.)	
		Signal characteristics		Starts single sweep at the rising edge.	
		Minimum pulse width		50ns	
		Connector		BNC receptacle on rear panel	
	Hold input	Input voltage		TTL Level (Input to 74LS14 is pulled up by 4.7kΩ)	
		Signal characteristics	Low	Holds sweep	
			High	Resumes sweep (releases HOLD condition)	
Connector		BNC receptacle on rear panel			
Output	Sweep sync output	Output voltage		TTL Level (100Ω is connected in series to the output of 74LS14)	
		Signal characteristics	Low	Indicates that sweep from the start frequency to the stop frequency is in progress.	
			High	Operation other than above	
		Connector		BNC receptacle on rear panel	
	Marker output	Output voltage		TTL Level (100Ω is connected in series to the output of 74LS14)	
		Signal characteristics	Low	Indicates that a signal of which frequency is higher than the marker frequency is being output during sweep.	
			High	Operation other than above.	
		Connector		BNC receptacle on rear panel	
	X drive output	Output voltage		0V to +10V (/OPEN)	
		Signal characteristics	0V → 10V	Frequency increasing	
			10V → 0V	Frequency decreasing	
		Output impedance		Approx. 600Ω, unbalanced	
		Load impedance		10kΩ minimum	
Connector		BNC receptacle on rear panel			

ELECTRICAL SPECIFICATIONS (CONT.)

Sub Synthesizer				
Waveforms	\sim , \square , \square , \wedge , ∇			
Frequency	Frequency range	0 to 100kHz		
	Display	Max. 10 digits, resolution 0.1mHz (fixed)		
	Accuracy	Identical to main synthesizer (identical clock source)		
	Setting in terms of period	Range	10 μ s to 10000s	
		Display	Max. 6 digits, minimum resolution 100ns	
Oscillates at a frequency that is the reciprocal of the set period (the reciprocal is rounded to the nearest number below 0.1mHz).				
Output Characteristics	Amplitude range	20Vp-p/open to 0.2Vp-p/open		
	Display	Units	Display	Display resolution
		Vp-p/open	Max. 3 digits	0.1Vp-p/open (fixed)
		Vrms/open	Max. 3 digits	0.1Vrms/open (fixed)
		dBV/open	Max. 3 digits and minus sign	0.1dBV/open (fixed)
	Amplitude resolution	Approx. 78.4mVp-p/open (fixed)		
	Amplitude accuracy	At frequency 1kHz, 5Vp-p/open minimum		
		\sim	$\pm 3\%$ (rms)	
		\square , \square , \wedge , ∇	$\pm 3\%$ (rms)	
	\sim Amplitude vs. frequency characteristics	Referenced to 1kHz, amplitude setting 2Vp-p/open minimum		
		10Hz to 50kHz	± 0.3 dB (rms)	
		50kHz to 100kHz	+1.0dB, -2.0dB (rms)	
	Total Harmonic Distortion	Amplitude setting 20Vp-p/open		
		10Hz to 20kHz	0.2% max	
		20kHz to 100kHz	0.3% max	
Output Impedance	Approx. 600 Ω , unbalanced			
Load Impedance	10k Ω minimum			
Connector	BNC receptacle on front panel			
Sync output	Output voltage	TTL Level (100 Ω is connected in series to the output of a 74LS14)		
	Connector	BNC receptacle on front panel		
Phase	Range	-360° to 360°		
	Display	Max. 4 digits and minus sign, resolution 0.1° (fixed)		
	Oscillation will enter the resume phase when the ϕ SYNC key is pressed or when the GPIB "SYN" command is given during single or master operation. In addition, oscillation will enter the resume phase when the ϕ SYNC key of the master unit is pressed or when the GPIB "SYN" command is given during slave operation.			

ELECTRICAL SPECIFICATIONS (CONT.)

Memory	
Memory contents	<p>Main Synthesizer Frequency¹, AC amplitude², DC offset³, waveform, oscillation mode</p> <p>For sweep Frequencies of start¹, stop¹, center¹, span¹, marker¹, sweep time⁴, sweep function</p> <p>For trigger Trigger source, stop level, mark wave cycle⁴, space wave cycle⁴, phase⁴</p> <p>Sub Synthesizer Frequency¹, AC amplitude⁵, waveform, phase⁴</p> <p>Others <input type="checkbox"/> Duty cycle⁴, 50% fixed/variable</p> <p>Notes: ¹Frequency display/terms of period display, cursor position and step size parameters saved. ²Voltage display with no load/display with 50Ω, display unit, cursor position and step size parameters saved. ³Voltage display with no load/display with 50Ω, cursor position and step size parameters saved. ⁴Cursor position and step size parameters saved. ⁵Display unit, cursor position and step size parameters saved.</p>
Number of memory units	10 units
Battery backup	30 days or more after full charge (stored at room temperature)

Storage of setting parameters at power off	
Functions	Parameters in effect prior to power-off are stored and become effective at next power-on.
Storage contents	Beep sound on/off, panel lock on/off, GPIB address, delimiter, and ARB waveforms, as well as items included in memory contents.
Battery backup	Identical to memory

ELECTRICAL SPECIFICATIONS (CONT.)

Preset

Sets the parameters listed below.

The modification step size is ± 1 . The underline indicates the cursor position.

Main Synthesizer

Frequency	<u>1</u> .0000000kHz (<u>1</u> .00000ms)
Amplitude	<u>1</u> 0.0mVp-p/open (<u>3</u> .54mVrms/open, - <u>4</u> 9.0dBV/no load, - <u>4</u> 2.0dBm/50 Ω)
DC offset	<u>0</u> .00mV/open
Waveform	<u>~</u>
Oscillation mode	CONT

For sweep

Start frequency	<u>1</u> .0000000kHz (<u>1</u> .00000ms)
Stop frequency	<u>1</u> 0.0000000kHz (<u>1</u> 00.00 μ s)
Center frequency	<u>5</u> .5000000kHz (<u>1</u> 81.818 μ s)
Frequency span	<u>2</u> .0000000kHz (<u>1</u> 11.111 μ s)
Marker frequency	<u>5</u> .0000000kHz (<u>2</u> 00.000 μ s)
Sweep time	<u>1</u> .000s
Sweep function	LIN <u>^</u>

For trigger

Trigger source	INT <u>v</u>
Stop level	HOLD
Mark wave cycle	<u>1</u> .0 cycle
Space wave cycle	<u>1</u> .0 cycle
Phase	<u>0</u> .0 deg

Sub Synthesizer

Frequency	<u>1</u> .0000000kHz (<u>1</u> .00000ms)
Amplitude	<u>1</u> .0Vp-p/open (0. <u>4</u> Vrms/open, - <u>8</u> .9dBV/open)
Waveform	<u>~</u>
Phase	<u>0</u> .0 deg

Others

<input type="checkbox"/> Duty cycle	50.0%
<input type="checkbox"/> Duty cycle 50%	fixed
Beep sound	ON

Display

Main parameter display of main synthesizer

ELECTRICAL SPECIFICATIONS (CONT.)

Modification			
Operation	By cursor movements with ◀ , ▶ keys (flashing display), and by increments/decrements with the Modify knob		
Increments/decrements with the Modify knob	Step size for cursor movement	± 1	Increases or decreases the cursor position value by 1.
		× + 2	Multiplies or divides the entire value by 2.
		× + 10	Multiplies or divides the entire value by 10.
	For waveform, oscillation mode, sweep function, trigger source, and stop level, the step size available is ±1 only and the cursor position is not displayed.		
Automatic repeat	Pressing the ◀ , ▶ keys for 0.3s or more causes automatic repeat.		
Non-modifiable parameters	Memory number, GPIB address, delimiter		

Signal Output ON/OFF			
Function	Simultaneously controls ON/OFF of FCTN OUT of the main synthesizer and the sub synthesizer. Factory default setting: Signal output ON at power-on.		
Operation	ON/OFF toggles each time the FCTN OUT ON/OFF key is pressed.		
OFF condition	Main synthesizer	FCTN OUT	Signal output will be open circuit.
		SYNC OUT	Identical to ON condition
	Sub synthesizer	FCTN OUT	Signal output will be 0V
		SYNC OUT	Signal output will stop oscillation at high level and low level

Other Functions	
Panel lock	Disables most front panel key entries and operating condition changes. Current parameter values can be displayed. GPIB input and certain BNC inputs are enabled.
Main synthesizer main parameter display	Main synthesizer frequency, waveform, oscillation mode, AC amplitude, DC offset, sweep condition are displayed together.
Sub synthesizer main parameter display	Sub synthesizer frequency, waveform, amplitude, phase are displayed together.
Calibration	Corrects main synthesizer AC amplitude error and offset error. FCTN OUT is OFF and SYNC OUT is undefined during calibration.
Beep sound ON/OFF	Controls ON/OFF of beep sound when panel keys are pressed (short beep), or when error has occurred (long beep).



B.2 GPIB INTERFACE



GPIB Interface		
Functions	SH1 AH1 T6 L4 SR1 RL1 PP0 DC1 DT0 C0	Full source handshaking capability Full acceptor handshaking capability Basic talker, serial poll, talker unaddressed if MLA Basic listener, unaddressed if MTA Full service request capability Full remote and local operation capability No parallel-polling function capability Full device clear capability No controller function capability No controller function capability
Data	ISO 7-bit code (ASCII code)	
Delimiter	Transmission	CR or CR/LF (selected by numeric keys on the panel) and EOI are sent simultaneously
	Reception	CR, CR/LF, CR + EOI, CR/LF + EOI, or EOI
Address	0 to 30 (selected by numeric keys on the panel)	
Output Driver	DIO1 to DIO8, NDAC, NRFD, SRQ	Open collector
	DAV, EOI	Tri-state
Local Key	Switch with return-to-local function	
Connector	IEEE-488 24-pin GPIB connector on rear panel	

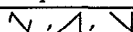

B.3 GENERAL

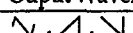

Signal Ground	The grounding pins of all input/output connectors are connected to the chassis.	
Power Supply	Voltage	100, 120, 220 or 240V AC $\pm 10\%$ (250V max)
	Frequency	48 to 62Hz
	Power Consumption	Approx. 70VA
Ambient Temperature and Humidity Ranges	Operating	0 to 40°C, 10 to 90% RH (without condensation)
	Storage	-10 to 50°C, 10 to 80% RH (without condensation)
Dimensions	Protruding parts not included	216 (W) \times 132.5 (H) \times 350 (D) mm 8.5 (W) \times 5-1/4 (H) \times 13-3/4 (D) in.
Weight	Approx. 5.6kg (12.5 lbs.)	

Table B-1. AC Amplitude Range for 0V DC Offset

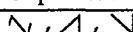
A. Values displayed with open load, Vrms units, in CONT mode			
AC Amplitude (p-p)	Output Waveforms		
			
20.Vp-p to 2.01Vp-p	7.07Vrms to 708.mVrms	5.77Vrms to 578.mVrms	10.0Vrms to 1.01mVrms
2.00Vp-p to 210.mVp-p	707.mVrms to 70.8mVrms	577.mVrms to 57.8mVrms	1.00mVrms to 101.mVrms
200.mVrmsVp-p to 20.1mVp-p	70.0mVrms to 7.08mVrms	57.7mVrms to 5.78mVrms	100.mVrms to 10.1mVrms
20.0mVp-p to 2.00mVp-p	7.07mVrms to 0.71mVrms	5.77mVrms to 0.58mVrms	10.0mVrms to 1.00mVrms

B. Values displayed with 50Ω load, Vrms units, in CONT mode			
AC Amplitude (p-p)	Output Waveforms		
			
10.0Vp-p to 1.01Vp-p	3.53Vrms to 354.mVrms	2.88Vrms to 289.mVrms	5.00Vrms to 501.mVrms
1.00Vp-p to 101.mVp-p	353.mVrms to 35.4mVrms	288.mVrms to 28.9mVrms	500.mVrms to 50.1mVrms
100.mVp-p to 10.1mVp-p	35.3mVrms to 3.54mVrms	28.8mVrms to 2.89mVrms	50.0mVrms to 5.01mVrms
10.0mVp-p to 1.00mVp-p	3.53mVrms to 0.36mVrms	2.88mVrms to 0.29mVrms	5.00mVrms to 0.50mVrms

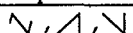
C. Values displayed with open load, dBV units, in CONT mode			
AC Amplitude (p-p)	Output Waveforms		
			
20.0Vp-p to 2.01Vp-p	16.9dBV to -3.0dBV	15.2dBV to -4.7dBV	20.0dBV to 0.1dBV
2.00Vp-p to 201.mVp-p	-3.1dBV to -23.0dBV	-4.8dBV to -24.7dBV	0.0dBVd to -19.9dBV
200.mVp-p to 20.1mVp-p	-23.1dBV to -43.0dBV	-24.8dBV to -44.6dBV	-20.0dBV to -39.9dBV
20.0mVp-p to 2.00mVp-p	-43.1dBV to -63.0dBV	-44.8dBV to -64.7dBV	-40.0dBV to -60.0dBV

D. Values displayed with 50Ω load, dBV units, in CONT mode			
AC Amplitude (p-p)	Output Waveforms		
			
10.0Vp-p to 1.01Vp-p	10.9dBV to -9.0dBV	9.2dBV to -10.7dBV	13.9dBV to -6.0dBV
1.00Vp-p to 101.mVp-p	-9.1dBV to -29.0dBV	-10.8dBV to -30.7dBV	-6.1dBV to -26.0dBV
100.mVp-p to 10.1mVp-p	-29.1dBV to -49.0dBV	-30.8dBV to -50.7dBV	-26.1dBV to -46.0dBV
10.0mVp-p to 1.00mVp-p	-49.1dBV to -69.0dBV	-50.8dBV to -70.7dBV	-46.1dBV to -66.0dBV



E. Values displayed with 50Ω load, dBm units, in CONT mode			
AC Amplitude (p-p)	Output Waveforms		
			
10.0Vp-p to 1.01Vp-p	23.9dBm to 4.0dBm	22.2dBm to 2.3dBm	26.9dBm to 7.0dBm
1.00Vp-p to 101.mVp-p	3.9dBm to -16.0dBm	2.2dBm to -17.7dBm	6.9dBm to -13.0dBm
100.mVp-p to 10.1mVp-p	-16.1dBm to -36.0dBm	-17.8dBm to -37.7dBm	-13.1dBm to -33.0dBm
10.0mVp-p to 1.00mVp-p	-36.1dBm to -56.0dBm	-37.8dBm to -57.7dBm	-33.1dBm -53.0dBm

Table B-2. AC Amplitude Resolution and Accuracy for 0V DC Offset (OPEN load)

Open load, CONT mode, frequency up to 10kHz, temperature within $\pm 5^{\circ}\text{C}$ of calibration temp.				
Output Amplitude Display	Amplitude Resolution	Amplitude Accuracy (RMS)		Output Attenuator
		\sim \square	All Other Waveforms	
20.Vp-p \geq display > 2.00mVp-p	10mVp-p	$\pm 2\%$	$\pm 3\%$	1/1
2.00Vp-p \geq display > 200.mVp-p	1mVp-p	$\pm 4\%$	$\pm 5\%$	1/10
200.mVp-p \geq display > 20.0mVp-p	100 μ Vp-p	$\pm 6\%$	$\pm 7\%$	1/100
20.0mVp-p \geq display > 2.00mVp-p	10 μ Vp-p	Not Specified		1/1000

Table B-3. Voltage Range, Resolution, and Accuracy for DC Only (OPEN load)

DC (+ or -)	Resolution	Accuracy	Output Attenuator
10.0V to 1.01V	5.0mV	$\pm(1\% + 20\text{mV})$	1/1
1.00V to 101.mV	500 μ V	$\pm(2\% + 2\text{mV})$	1/10
100.mV to 10.0mV	50 μ V	$\pm(3\% + 0.2\text{mV})$	1/100
10.0mV to 0.00mV	5.0 μ V	Not specified	1/1000

Table B-4. Minimum AC Amplitude, Resolution, and DC Voltage Accuracy for AC + DC (OPEN load)

Open load, CONT mode, frequency up to 10kHz, temperature within ±5°C of calibration temperature				
Total Set Voltage*	>1V	>100mV	>10mV	≤10mV
Minimum AC Amplitude	200mVp-p	20mVp-p	2mVp-p	2mVp-p
AC Amplitude Resolution	10mVp-p	1mVp-p	0.1mVp-p	10mVp-p
DC Voltage Resolution	5mVp-p	0.5mVp-p	50μVp-p	5mVp-p
DC Voltage Accuracy	When AC amplitude is >2.00V ±(0.5% of AC amplitude + 1% of DC offset voltage +20mV)	When AC amplitude is >200mV ±(0.5% of AC amplitude + 2% of DC offset voltage +2mV)	When AC amplitude is >20.0mV ±(0.5% of AC amplitude + 3% of DC offset voltage +0.2mV)	Not Specified
	When AC amplitude is ≤2.00V ±(1% of AC amplitude +2% of DC offset voltage +40mV)	When AC amplitude is ≤200mV ±(1% of AC amplitude +3% of DC offset voltage +4mV)	When AC amplitude is ≤20.0mV ±(1% of AC amplitude +4% of DC offset voltage +0.4mV)	Not specified
Output Attenuator	1/1	1/10	1/100	1/1000
$*Total\ Set\ Voltage = \frac{Set\ AC\ Amplitude\ (Vp-p)}{2} + Set\ DC\ Voltage\ (V) $				

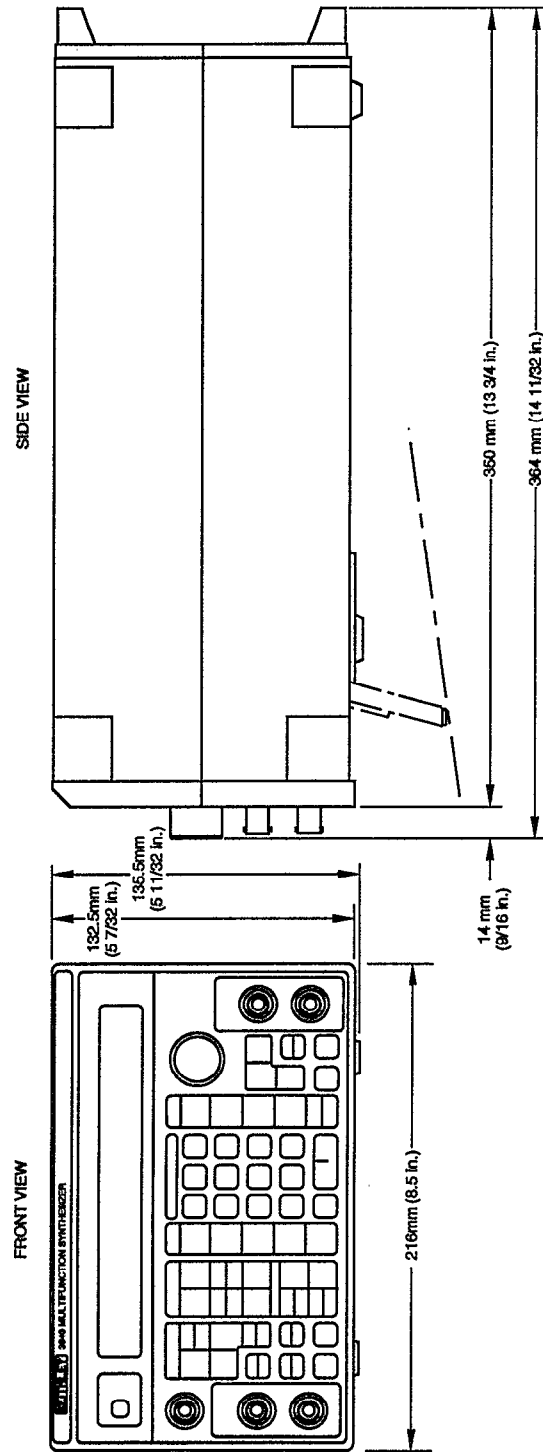

Figure B-1. Outer Dimensions of the Model 3940

Index

A

Amplitude Accuracy, 1-4
Amplitude Control, 2-3

B

Block Diagram, 2-1
Board-Level Repair, 3-11

C

Calibration, 2-3, 3-1
Calibration Procedures, 3-6
Control Section, 2-1
Cover Removal, 3-2
Cover Replacement, 3-8

D

D/A Converter, 2-3
DC Level (Square) and DC Offset Error (Sine),
1-11
DC Voltage Accuracy, 1-10
Display and Keyboard Section, 2-1

E

Environmental Conditions, 1-1, 3-2

F

Factory Service, 3-9
Fan Filter Cleaning, 3-9
Frequency Accuracy, 3-6
Frequency and Duty Cycle Accuracy, 1-2
Frequency Response (Sine), 1-6
Frequency Response (Sub Sine), 1-8
Frequency Response (Triangle, Sawtooth,
Square), 1-7

G

GPIB Interface, 2-1

I

Initial Conditions, 1-1, 3-2

L

Line Fuse Replacement, 3-1
Line Power, 3-2
Line Power Voltage, 1-1

M

Main Synthesizer, 2-3

Main Synthesizer Amplitude Accuracy, 3-7
Main Synthesizer Block Diagram, 2-3
Main Synthesizer DC Offset Accuracy, 3-8
Main Synthesizer Description, 2-3

O

Ordering Parts, 3-11
Output Amplifier, 2-3

P

Parts List, 3-11
Performance Verification, 1-1
Power Supply, 2-3
Power Supply Test Points, 3-9
Principles of Operation, 2-1

R

Rechargeable Battery Replacement, 3-9
Recommended Calibration Equipment, 3-2
Recommended Test Equipment, 1-1
Repair, 3-9
Replaceable Parts, 3-11

S

Service Information, 3-1
Square Wave Duty Cycle, 3-8
Square Wave Generator, 2-3
Sub Synthesizer, 2-3

Sweep Section, 2-1
Synthesizer Operating Principles, 2-5

T

Total Harmonic Distortion, 1-8

Trigger Section, 2-1

V

Verification Procedures, 1-2

KEITHLEY INSTRUMENTS

SERVICE FORM

Model No. _____ Serial No. _____ Date _____

Name and Telephone No. _____

Company _____

List all control settings, describe problem and check boxes that apply to problem. _____

- Intermittent Analog output follows display Particular range or function bad; specify _____
 IEEE failure Obvious problem on power-up Batteries and fuses are OK
 Front panel operational All ranges or functions are bad Checked all cables

Display or output (circle one)

- Drifts Unable to zero
 Unstable Will not read applied input
 Overload

Calibration only Certificate of Calibration required

Data required

(attach any additional sheets as necessary.)

Show a block diagram of your measurement system including all instruments connected (whether power is turned on or not). Also, describe signal source.

Where is the measurement being performed? (factory, controlled laboratory, out-of-doors, etc.)

What power line voltage is used? _____ Ambient Temperature? _____ °F

Relative humidity? _____ Other? _____

Any additional information. (If special modifications have been made by the user, please describe.) _____

Be sure to include your name and phone number on this service form.

KEITHLEY INSTRUMENTS

Instruments Division, Keithley Instruments, Inc. • 28775 Aurora Road • Cleveland, Ohio 44139 • (216) 248-0400 • Fax: 248-6168

WEST GERMANY: Keithley Instruments GmbH • Heighofstr. 5 • Munchen 70 • 089-71002-0 • Telex: 52-12160 • Fax: 089-7100259
GREAT BRITAIN: Keithley Instruments, Ltd. • The Minster • 58, Portman Road • Reading, Berkshire RG 3 1EA • 011 44 734 575 666 • Fax: 011 44 734 596 469
FRANCE: Keithley Instruments SARL • 3 Allee des Garays • B.P. 60 • 91124 Palaiseau/Z.I. • 1-6-0115 155 • Telex: 600 933 • Fax: 1-6-0117726
NETHERLANDS: Keithley Instruments BV • Avelingen West 49 • 4202 MS Gorinchem • P.O. Box 559 • 4200 AN Gorinchem • 01830-35333 • Telex: 24 684 • Fax: 01830-30821
SWITZERLAND: Keithley Instruments SA • Kriesbachstr. 4 • 8600 Dubendorf • 01-821-9444 • Telex: 828 472 • Fax: 0222-315366
AUSTRIA: Keithley Instruments GesmbH • Rosenhugelstrasse 12 • A-1120 Vienna • (0222) 84 65 48 • Telex: 131677 • Fax: (0222) 8403597
ITALY: Keithley Instruments SRL • Viale S. Gimignano 4/A • 20146 Milano • 02-4120360 or 02-4156540 • Fax: 02-4121249